

SIGNATURES OF SURFACES IN 3-MANIFOLDS
AND APPLICATIONS TO KNOT AND LINK COBORDISM

by Daryl Cooper

Submitted for the degree of Ph D

at Warwick University

Institute of Mathematics

August 1982

Summary

This thesis has two chapters. The first investigates necessary conditions for a classical knot to be slice, improving on some results obtained by Casson and Gordon. The method is to study a Seifert form on an arbitrary surface in an arbitrary 3-manifold M . By analogy to the Seifert form of a knot, certain numerical signature invariants of the surface are defined. These signatures turn out to be bounded when a closed surface bounds a 3-manifold in some 4-manifold whose boundary is M ; this is the principle tool. It is used to study surfaces lying in certain cyclic coverings of a knot. A non-embedding result is given for 3-manifolds in 4-manifolds in which $\beta_1 = 0$.

Chapter two is an analysis of the $\mathbb{Z} \oplus \mathbb{Z}$ cover of a classical link of two components studied by means of a generalisation of the Seifert pairing defined on transverse Seifert surfaces for the link components. This enables a signature function to be defined on the torus generalising the knot signature function on the circle. A new proof is given of the form of the Alexander polynomial for a slice link. A proof of some of Conway's relations between link polynomials is given. And in §4, certain polynomials are shown to arise from links, showing in particular that the Torres conditions are sufficient for linking number two when the components are unknotted.

Contents

Chapter 1 Detecting Knots which are not Slice

1. Introduction	1
2. Calculus of Signatures	3
The Signature Theorem	11
Additivity Theorems	18
Finiteness Theorem	24
Parallel Surfaces Theorem	25
3. Slice Knots	28
The Knot 8_{20}	30
Remark on Surgery curves	36
Genus One Slice Knots	37
4. Connection with G-signatures	45
5. Further Results and Problems	53

Chapter 2 The Universal Abelian Cover of a Link

1. Introduction	55
2. The Algorithm	56
3. Homology of the $(\mathbb{Z} \oplus \mathbb{Z})$ cover	60
4. Generating Link polynomials	72
5. Cobordism Invariance of Polychrome signature	83
The Isotopy Lemma	83
6. Interpretation of Polychrome signatures in terms of G-signatures	96

Contents (Cont.)

7. Applications	107
Mutations are S-equivalent	107
Normalising the Alexander Polynomial	108
The Signature and polynomial of amphiceiral links	110
Counting the intersections between a curve and a surface	110
Identities between Alexander polynomials	111
An Identity for Polychrome signature	113
8. Further Remarks and Problems	114
References	115

1. Introduction

A knot k in S^3 is slice if it is the boundary of a smooth disc properly embedded in B^4 . A Seifert surface V for k defines a Seifert pairing S_V on $H_1(V)$ defined by lifting a representative cycle off V using the normal orientation to V defined by the orientations of k and S^3 , and taking the linking number with another cycle lying on V . That k is slice ensures the existence of a subspace of $H_1(V)$ of half dimension on which S_V vanishes. A knot whose Seifert pairing satisfies this condition is called algebraically slice. Analogous definitions may be made in higher (odd) dimensions, and in this case the concepts of slice and algebraically slice coincide (L2). The idea is to convert a Seifert surface V lying in S^{2n+1} into a disc in B^{2n+2} by doing embedded surgery, this works up to the middle dimension where the Seifert pairing appears as the only obstruction. Trying to carry out this program in the classical case means finding a set of g (=genus V) simple closed curves on V which bound disjoint smooth discs in B^4 , and then surgering V along these discs to produce a slice disc.

This suggests taking a Seifert surface V for a slice knot k having these surgery curves, and regarding V as a disc with bands around which these curves run, tying one of the bands into a knot K (without adding any twists) so that a surgery curve is knotted. The resulting knot k' has the same Seifert pairing as k and will be slice if K is slice, indeed the surgery curves on the modified V still work. However if K is not slice one might suspect that k' is not slice, indeed one might conjecture that if K is not algebraically slice then k' is not slice. This generalises a well known conjecture that the untwisted double of a knot (= do above

operation to a genus 1 surface for the unknot) is slice if and only if the original knot was (algebraically) slice. In section 3, k' is shown not to be slice when k is a genus 1 knot with non trivial Alexander polynomial (thereby excluding the unknot) for certain K . On the way an obstruction is found to embedding (orientable) 3-manifolds in 4-manifolds when the map on two dimensional homology is not injective. In particular given $n > 0$ there is a 3-manifold M which will not embed smoothly in any closed oriented 4-manifold W with $\beta_2(W) < n$ and $\beta_1(W) = 0$.

The existence of algebraically slice knots which are not slice was first proved by Casson and Gordon (CG) using the G-signature theorem. The present results are obtained using elementary methods in sections 2 and 3, however a relation to the G-signature theorem is given in section 4.

Notation and Conventions

All work is done in the PL category with local flatness and in dimensions ≤ 4 , or alternatively in the smooth category. Manifolds are compact and oriented, orientations are preserved everywhere. Throughout \cdot is the intersection pairing on (singular) homology both at the chain level and on homology groups. $^\perp$ is used for orthogonal (usually with respect to \cdot) complement of a vector space, and \oplus is used for orthogonal direct sum. When complex (\mathbb{C}) coefficients are used all pairings (including \cdot) are sesquilinear. An un-named map between topological spaces, or a map named i , will usually be an inclusion unless otherwise stated. $\omega, \omega_1, \omega_2$ are complex numbers of unit modulus, V is a surface M a 3-manifold and W a 4-manifold.

Familiarity with the Seifert pairing in classical knot theory is assumed together with properties of the infinite cyclic cover of a knot complement derived from it, as presented in (G). The numbering scheme used is s.t where s is a section number within a chapter, t is a 'topic'. The same scheme is used independantly for diagrams.

§2 Calculus of Signatures

In this section numerical invariants are obtained from any oriented surface in any oriented 3-manifold. The main result is the Signature theorem (2.10) which places a restriction on the signature of a closed surface sitting in the boundary of a 4-manifold and bounding a 3-manifold in that 4-manifold. The other main tools are the Additivity theorems (2.19, 2.20) which connect the signatures obtained by glueing together 3-manifolds and/or surfaces in them.

2.1 Definition

Suppose V is an oriented surface embedded in an oriented 3-manifold M such that $\text{int}(V)$ lies in $\text{int}(M)$ and if S is a boundary component of V either S lies in $\text{int}(M)$ or else V is properly embedded in M along S , ie. $S \times [0,1] \rightarrow V \rightarrow M$ is a proper embedding. This ensures a normal bundle for S in M , let $i_-: V \rightarrow M$ be the (-1) section of this bundle, the orientation of the normal bundle being induced by those of V and M . Define

$$K_V = \ker \{i_{-*}: H_1(V; \mathbb{C}) \rightarrow H_1(M; \mathbb{C})\}$$

and define a sesquilinear Seifert form

$$S_V: K_V \otimes K_V \rightarrow \mathbb{C}$$

$$\text{by } S_V(\{\alpha\} \otimes a, \{\beta\} \otimes b) = a \bar{b} \cdot \text{Lk}(i_{-*}\alpha, \beta)$$

where $a, b \in \mathbb{C}$ and $\{\alpha\}, \{\beta\} \in H_1(V; \mathbb{R})$

(linking number is uniquely defined between 1-boundaries)

Given $\omega \in \mathbb{C}$ with $|\omega| = 1$ define an Hermitian Seifert form

$$S_{\omega, V, M}: K_V \otimes K_V \rightarrow \mathbb{C}$$

$$\text{by } S_{\omega, V, M}(\alpha, \beta) = (1 - \omega) S_V(\alpha, \beta) - \bar{\omega} S_V(\beta, \alpha)$$

denote the signature of this by $\sigma(\omega, V, M)$ and define

$$\tau(\omega, V, M) = \frac{1}{2} \lim_{\epsilon \rightarrow 0^+} \{ \sigma(\omega e^{i\epsilon}, V, M) + \sigma(\omega e^{-i\epsilon}, V, M) \}$$

(little distinction is drawn between cycles and the homology classes they represent)

2.2 Examples

1) $M=S^3$, V is a Seifert surface for a knot k lying in S^3 , then the signature obtained is a well known invariant of k , independent of V .

If A is a Seifert matrix for k obtained from V , the Alexander polynomial of k is $\Delta(t)=\det(tA-A')$ see (G) p 24. Then $\sigma(\omega,V,M)$ is the signature of $(1-\omega)(A-\bar{\omega}A')$ and is thus constant except at roots of $\Delta(t)$. Taking the average of the 1-sided limits ensures that $\tau(\omega,V,M)=0$ for all ω when k is a slice knot, see (G) p 37, his definition of τ_k . We will write $\sigma(\omega,k)=\sigma(\omega,V,M)$ in this case. If k is the right hand trefoil knot 3_1 then

$$\sigma(e^{i\theta}, k) = \begin{cases} 0 & |\theta| < \pi/6 \\ -1 & |\theta| = \pi/6 \\ -2 & \pi/6 < \theta < 11\pi/6 \end{cases}$$

as is seen from a Seifert surface and matrix :

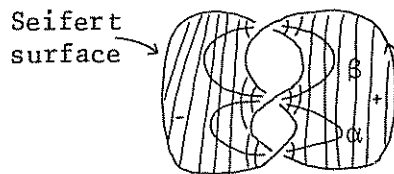

$$A = \begin{bmatrix} \alpha & \beta \\ -1 & 1 \\ 0 & -1 \end{bmatrix}$$

- 2) Given a knot k in S^3 , perform 0-framed surgery (see (R) p 257) along K to produce a manifold we shall denote by $M(k)$. Then $M(k)$ has the homology of $S^1 \times S^2$, and a generator of H_2 is represented by a Seifert surface + core of handle (0-framing ensures their boundaries coincide) It is clear that $K_V = H_1(V)$ for this surface, and that $\sigma(\omega,V,M) = \sigma(\omega,k)$. Incidentally if $-V$ denotes the surface with the opposite orientation $\sigma(\omega,-V,M) = \sigma(\omega,V,M)$ (the change of orientation transposes the Seifert form) hence $\sigma(\omega,-,M)$ is not a homomorphism from $H_2(M)$. In fact 2.26 says that $\sigma(\omega,nV,M) = \sigma(\omega|n|,V,M)$ for $n \in \mathbb{Z}$.
- 3) $M=S^1 \times S^2$, $V=S^1 \times S^1$, $\dim K_V=1$ and the Seifert form is zero, thus singular (see 2.11).

- 4) V is a closed surface of genus g , $M=V \times S^1$ then $K_V=0$.
- 5) $M=L_{p,q}$ a Lens space. M may be viewed as a solid torus T to which a 2-handle is attached along a simple closed curve winding q times meridionally and p times longitudinally, and a 3-handle added to close the manifold. $V=\partial T$, a torus. If coefficients \mathbb{Z} instead of \mathbb{C} are used then $H_1(V)/K_V \cong \mathbb{Z}_p$ ($\cong \mathbb{Z}/p\mathbb{Z}$ in this thesis) and the Seifert form has matrix

$$\begin{bmatrix} 0 & p \\ 0 & 0 \end{bmatrix}$$

- 6) M is obtained by doing 0-framed surgery along two unknotted circles a and b , in S^3 shown in (i)

(i)



(ii)

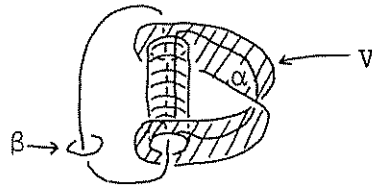

$H_2(M; \mathbb{Z}) \cong 2\mathbb{Z}$. Let V be the genus 1 surface shown in (ii) + core of handle a then $K_V \cong \mathbb{Z}$ generated by α and the Seifert form has 1×1 matrix $(+1)$, so $\sigma(\omega, V, M) = +1$. This manifold will be referred to later as Ω . Now remove from Ω a solid torus neighbourhood of the curve β (a meridian of b) shown in (ii), and call this manifold Ω_β .

Frequent use will be made of duality in manifolds, and in particular the following consequences :

Duality Properties

For a compact 3-manifold M

$$(1) \quad 2\text{nullity}\{i_*: H_1(\partial M) \rightarrow H_1(M)\} = \beta_1(\partial M)$$

$$(2) \quad \text{If } a, b \in \ker\{i_*: H_1(\partial M) \rightarrow H_1(M)\} \text{ then } a \cdot b = 0 \quad (\cdot \text{ in } \partial M)$$

For a compact 4-manifold W

$$(3) \quad \text{Radical } (\cdot | H_2(W)) = \text{Im}\{i_*: H_2(\partial W) \rightarrow H_2(W)\}$$

$$(4) \quad \ker\{i_*: H_1(\partial W) \rightarrow H_1(W)\} \text{ is dually paired to}$$

$$H_2(\partial W) / \ker\{i_*: H_2(\partial W) \rightarrow H_2(W)\} \text{ in } \partial W.$$

2.3 Definition

It will sometimes be more convenient to consider another sesquilinear form

$$I_V : H_2(M, V; \mathbb{C}) \otimes H_2(M, V; \mathbb{C}) \longrightarrow \mathbb{C}$$

defined by $I_V(a, b) = S_V(\partial a, \partial b)$ where $\partial : H_2(M, V) \longrightarrow H_1(V)$

is the boundary homomorphism. Another way of thinking of I_V is to notice that in $M \times I$, $I_V(a, b) = i_{-} a \cdot b$ is the sesquilinear intersection pairing between 2-chains $a, b \in Z_2(M \times I, M \times 0)$ with disjoint boundaries. i_{-} is the automorphism of $M \times I$, extended from M using the product structure, and the defined on M to be λ identity outside a neighbourhood of V and taking V to the (-1) section of its normal bundle. Define a Hermitian form by

$$I_{\omega, V, M}(a, b) = S_{\omega, V, M}(\partial a, \partial b)$$

and note that $\sigma(\omega, V, M) = \sigma(I_{\omega, V, M})$ because ∂ is a surjection onto K_V .

K_V has some additional structure, let $X = \text{cl}(M - V \times I)$ and consider the commutative diagram (for V closed)

$$\begin{array}{ccccc} H_2(M, \partial M) & \longrightarrow & H_2(M, X) & \xrightarrow[\text{excision}]{\cong} & H_2(V \times I, V \times \partial I) \\ & \searrow \Delta_+ \oplus \Delta_- & & & \downarrow \partial_+ \oplus \partial_- \\ & & & & H_1(V) \oplus H_1(V) \end{array}$$

$\partial_+ \oplus \partial_-$ is the boundary homomorphism for the pair $V \times I, V \times \partial I$ composed with the natural isomorphism $H_1(V \times \partial I) \rightarrow H_1(V) \oplus H_1(V)$. Define :

$$L_V = \text{Im } \Delta_+ \quad (= \text{Im } \Delta_-)$$

$$J_V = L_V \cap L_V^\perp \quad \perp \text{ with respect to } \cdot \text{ on } H_1(V)$$

$$R_{\omega, V, M} = \text{Radical of } S_{\omega, V, M}$$

2.4 Structure of K_V

If V and M are closed then :

- (1) $K_V = L_V^\perp$ so $J_V \leq K_V$
- (2) The radical of $\cdot | K_V$ is J_V
- (3) $R_{\omega, V, M} \cap R_{\omega', V, M} \leq J_V$ if $\omega \neq \omega'$, $\omega, \omega' \neq 1$

Proof: if $a \in H_2(M)$ $\beta \in K_V$ then

the intersection in V $\beta \cdot \Delta_+(a) = \beta \cdot a$ as an intersection in M
 $= 0$ since β is a boundary

hence $K_V \leq L_V^\perp$. The rows of the commutative diagram below are the exact sequences of the pairs $(X, Vx\partial I)$ and (M, VxI) the sequences are connected by maps induced by inclusion.

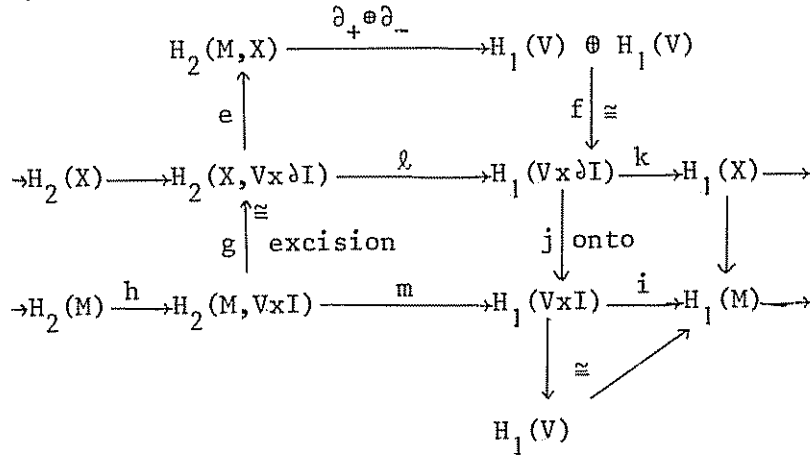

$$\begin{aligned}
 \dim \ker k &= \dim (j \ker k) + \dim (\ker j \cap \ker k) && \text{trivially} \\
 &= \beta_1(V) && \text{by duality in } X \text{ since} \\
 & && \partial X = Vx\partial I
 \end{aligned}$$

$$\begin{aligned}
 j \ker k &= \text{Im } j\ell && \text{by exactness} \\
 &= \text{Im } m && \text{by commutivity} \\
 &= \ker i && \text{by exactness} \\
 &= K_V && \text{by definition}
 \end{aligned}$$

$$\begin{aligned}
 \ker j \cap \ker k &= \ker j \cap \text{Im } \ell && \text{by exactness} \\
 &= \ell g \ker m && \text{by commutivity} \\
 &= \text{Im } \ell g h && \text{by exactness} \\
 &= \text{Im } f(\partial_+ \oplus \partial_-) e g h && \text{by commutivity}
 \end{aligned}$$

now $\Delta_+ = \partial_+ e g h$ hence $L_V = \text{Im } \partial_+ e g h$ and because $\ker \partial_+ = \ker(\partial_+ \oplus \partial_-)$

$$\begin{aligned}
 \text{it follows that } \dim L_V &= \text{rk}(\partial_+ \oplus \partial_-) e g h \\
 &= \text{rk } f(\partial_+ \oplus \partial_-) e g h && \text{because } f \text{ is injective}
 \end{aligned}$$

hence $\beta_1(V) = \dim K_V + \dim L_V$. Now V is closed so the intersection

pairing on it is non-singular hence $\dim L_V^\perp + \dim L_V = \beta_1(V)$

thus $\dim K_V = \dim L_V^\perp$, proving (1).

$$\begin{aligned} \text{for (2) we have } J_V &= L_V \cap L_V^\perp \\ &= K_V \cap K_V^\perp \quad \text{by (1)} \end{aligned}$$

the last term is the radical of $\cdot | K_V$.

For (3) suppose $\alpha \in R_{\omega, V, M} \cap R_{\omega', V, M}$ then for $\beta \in K_V$

$$\begin{aligned} 0 &= S_{\omega, V}(\alpha, \beta) - \frac{1-\omega}{1-\omega'} S_{\omega', V}(\alpha, \beta) \\ &= (1-\omega)S_V(\alpha, \beta) + (1-\bar{\omega})S_V(\beta, \alpha) - (1-\omega)S_V(\alpha, \beta) - \frac{1-\omega}{1-\omega'}(1-\bar{\omega}')S_V(\beta, \alpha) \\ &= S_V(\beta, \alpha) (1-\bar{\omega})(1-\omega\bar{\omega}') \end{aligned}$$

the hypotheses exclude $(1-\bar{\omega})(1-\omega\bar{\omega}')=0$

hence $S_V(\beta, \alpha)=0$, and swapping α and β gives $S_V(\alpha, \beta)=0$.

However $S_V(\alpha, \beta) - S_V(\beta, \alpha) = \alpha \cdot \beta$ intersection on V . Thus $\alpha \cdot \beta = 0$

for all $\beta \in K_V$, so $\alpha \in J_V$ by (2), proving (3).

2.5 The Radical Lemma

Let $p: K_V \rightarrow J_V$ be any projection onto the subspace J_V of K_V . Then except for finitely many ω , p is injective on $R_{\omega, V, M}$.

Proof: choose any $K' \leq K_V$ such that $K_V = K' \oplus J_V$, we must show that $R_{\omega, V, M} \cap K'$ is zero except for finitely many ω . Let A be a matrix for $S_{V, M} | K'$ using some basis. Define $f(t) = \det(A - tA')$ then $f(1) \neq 0$ because $A - A'$ is the matrix of the intersection pairing on K' , which is non-singular because, by 2.4, $J_V = \text{Radical}(\cdot | K_V)$. $f(t)$ is a polynomial in t and so $(1-\omega)(A - \bar{\omega}A')$ is singular for finitely many values of ω only. This is the matrix of $S_{\omega, V, M} | K'$ which accordingly is a non-singular Hermitian form except for these ω .

2.6 Piecewise Constancy of σ

σ as a function of ω is constant except at finitely many values so $\tau = \sigma$ except at these values.

Proof: Let A be a Seifert matrix for the Seifert form $S_{V,M}$.

$M = (1-t)(A-t^{-1}A')$ is a matrix over $F=\mathbb{Q}(t)$ and Hermitian with respect to the involution $t \rightarrow t^{-1}$ of F . There is $P \in GL_n(F)$ such that $PM\bar{P}'$ is diagonal with entries rational functions of t . Replacing t by ω in this matrix (ω not a zero of a denominator) and taking its signature gives $\sigma(\omega, V, M)$ which is accordingly constant away from the zeroes of the numerators and denominators of entries of P and $PM\bar{P}'$, giving the result.

2.7 Proposition

Suppose V_0 and V_1 are oriented surfaces properly embedded in an oriented 3-manifold M with $\partial V_0 = \partial V_1$ and $\{V_0\} = \{V_1\} \in H_2(M, \partial M)$. Then there is another such surface V obtainable from both V_0 and V_1 by a

- sequence of
- (S0) Ambient Isotopy
 - (S1) Adding a disjoint 2-sphere which bounds a 3-ball
 - (S2) Adding a hollow handle

Sketch proof (from (G) p 27.)

Construct maps $p_0, p_1 : M \rightarrow S^1$ transverse regular at the point x of S^1 with $p_i^{-1}(x) = V_i$. The hypotheses ensure a map $p : M \times I \rightarrow S^1$ with $p|_{M \times i} = p_i$ $i=0,1$. Again this may be chosen transverse regular at x so $p^{-1}(x)$ is a 3-manifold U with $\partial U = V_0 \times 0 \cup \partial V_1 \times I \cup V_1 \times 1$. Now take a collar level-handle decomposition of U in which the 0- and 1- handles are added before the 2- and 3- handles. Then taking a level section of U above the 0- and 1- handles & below the 2- and 3- handles gives the surface V , completing the proof.

2.8 Remark in oriented compact manifolds codimension one homology is representable by properly embedded submanifolds (with trivial normal bundle)

2.9 Invariance of σ

With the hypotheses of (2.7) $\sigma(\omega, V_0, M) = \sigma(\omega, V_1, M)$

Proof: Clearly S0 and S1 have no effect on σ , so suppose that V' is obtained from V by S2. $K_{V'}$ is larger than K_V because a meridian m of the handle (=attaching circle) bounds a disc in V and so represents a new class in $K_{V'}$. This leaves any 'longitude' ℓ running round the new handle (ie. meeting m once transversely) which may or may not be in $K_{V'}$. If $\alpha \in K_V$ then $S_V(\alpha, m) = 0 = S_V(m, \alpha)$ because m bounds a disc disjoint from V' . If $\ell \in K_{V'}$, then without loss $S_V(\ell, m) = 1$ $S_V(m, \ell) = 0$ and it follows that irrespective of whether $\ell \in K_V$, $\sigma(\omega, V, M) = \sigma(\omega, V', M)$ completing the proof.

If $\{V_0\} = \{V_1\} \in H_2(M, \partial M)$ but $\partial V_0 \neq \partial V_1$ it is not the case that $\sigma(\omega, V_0, M) = \sigma(\omega, V_1, M)$ necessarily. To illustrate this consider Ω_β from example 6 of (2.2), the closed surface V given has $\sigma(\omega, V, \Omega_\beta) = 1$, however β lies in the normal bundle of V , and so V may be isotoped to V' meeting $\partial\Omega_\beta$ in $\beta \times I$. Then $\{V' - \beta \times I\} = \{V\} \in H_2(\Omega_\beta, \partial\Omega_\beta)$ but because $\beta \times I$ cuts α , $K_{V'} = 0$ and so $\sigma(\omega, V' - \beta \times I, \Omega_\beta) = 0$. This example relies on the fact that $\alpha \in J_V$ This would seem to rule out a natural interpretation of σ (section 4) when $\partial M \neq 0$.

We are now ready for the Signature theorem which will be our main tool. It is a generalisation of Levine's statement (and proof) of the vanishing of signature for slice knots (L2). A different version is proved in section 4 using the G-signature approach, which suggests the effect of $R_{\omega, V, M}$ is not important.

2.10 The Signature Theorem

If U is a compact oriented 3-manifold properly embedded in W a compact oriented 4-manifold and $(M, V) = \partial(W, U)$ then,

$$\begin{aligned} |\sigma(\omega, V, M) + \sigma(W)| &\leq \text{rk}(\cdot | H_2(W)) + \dim\{K_V/R_{\omega, V, M}\} \\ &\quad - 2\text{nullity}\{i_*: K_V/R_{\omega, V, M} \longrightarrow H_1(U)/i_*R_{\omega, V, M}\} \\ &\leq \text{rk}(\cdot | H_2(W)) + \beta_1(V) - \dim\{K_V/R_{\omega, V, M}\}. \quad \text{Also} \\ |\sigma(\omega, V, M) + \sigma(W)| &\leq \beta_2(W) + \beta_1(M) \quad \text{except for finitely many } \omega \end{aligned}$$

Proof: Coefficients \mathbb{C} are used throughout this proof. Given ω define a Hermitian form (extending the definition of $I_{\omega, V, M}$)

$$I_{\omega}: H_2(W, V) \otimes H_2(W, V) \longrightarrow \mathbb{C}$$

by $I_{\omega}(\{a\}, \{b\}) = (1 - \omega)(i_{-*}a \cdot b - \bar{\omega} i_{+*}a \cdot b)$ where $a, b \in Z_2(W, V)$. i_{-} is an automorphism of W fixed outside a neighbourhood of U and with $i_{-}|_U$ the (-1) section of the normal bundle of U , the sign being determined by the orientations of U and W . To see that I_{ω} is uniquely determined suppose $\{b\} = 0 \in H_2(W, V)$, then $\{b\} = 0 \in H_2(W, \partial W)$ now $i_{-*}a, b \in Z_2(W, \partial W)$ and have disjoint boundaries so $i_{-*}a \cdot b = i_{-*}\{a\} \cdot \{b\}$ intersection in $H_2(W, \partial W)$
 $= 0$ since $\{b\} = 0 \in H_2(W, \partial W)$
 and so $I_{\omega}(\{a\}, \{b\}) = 0$.

The radical of the intersection pairing on $H_2(W)$ is

$$C = \text{Im}\{i_*: H_2(\partial W) \longrightarrow H_2(W)\} \text{ so choose a splitting } H_2(W) = C \oplus A.$$

The exact sequence of the pair W, V is

$$H_2(V) \xrightarrow{\circ} H_2(W) \longrightarrow H_2(W, V) \xrightarrow{\partial} H_1(V) \xrightarrow{i} H_1(W) \longrightarrow$$

which splits (non naturally) giving

$$(1) \quad H_2(W, V) = A \oplus (C \oplus B)$$

where $\partial: B \xrightarrow{\cong} \ker i$ (the orthogonality $B \perp A^{\perp}$ is possible because $\cdot | A$ is non-singular). There is a natural isomorphism

$$\ker i \cong \ker \{j_*: H_1(V) \longrightarrow H_1(M)\} \oplus \{\text{Im } H_1(V) \longrightarrow H_1(M) \cap \ker H_1(M) \longrightarrow H_1(W)\}$$

pull back this decomposition via ∂ to B giving $B = D \oplus E$, where

$$D = \partial^{-1} \ker j_* \quad \text{and} \quad E = \partial^{-1}(\text{other term}). \text{ We may suppose that } B \text{ was}$$

chosen so that $D \oplus C = \text{Im} \{H_2(M, V) \rightarrow H_2(W, V)\}$ because $A \cdot H_2(M, V) = 0$.

From (1) we get $\sigma(I_\omega) = \sigma(I_\omega|A) + \sigma(I_\omega|B \oplus C)$

observe that if $\partial a = 0$ or $\partial b = 0$ then $I_\omega(\{a\}, \{b\}) = (1 - \omega + 1 - \bar{\omega})\{a\} \cdot \{b\}$

that is to say I_ω is a multiple of the intersection pairing \cdot

and so $\sigma(I_\omega|A) = \sigma(W)$, also :

(2) $C \cdot C = 0$ because $\partial C = 0$ and $C = \text{Radical}(\cdot|H_2(W))$

(3) $C \cdot D = 0$ because of the way D was chosen

(4) $\text{rk}(\cdot|C \oplus E) = \dim E$ because $\partial E \leq \ker\{H_1(\partial W) \rightarrow H_1(W)\}$ is dually paired to $C = \text{Im}\{H_2(\partial W) \rightarrow H_2(W)\}$.

We have the following situation, a Hermitian form I_ω is defined on $C \oplus D \oplus E$

and $C \leq \text{Radical}(I_\omega|C \oplus D)$ and E is non singularly paired by I_ω into C

thus $\sigma(I_\omega|C \oplus D \oplus E) = \sigma(I_\omega|D) = \sigma(I_\omega|C \oplus D)$

Now $\sigma(I_\omega|D) = \sigma(\omega, V, M)$ by definition of $C \oplus D$ hence

(5) $\sigma(I_\omega) = \sigma(W) + \sigma(\omega, V, M)$.

The idea now is to get a bound on σ from the vanishing of I_ω

on a certain subspace. I_ω may be singular so the appropriate result is that if the dimension of the space I_ω is defined on is d , the dimension of it's radical, R_ω say, is r and the dimension of a subspace on which it vanishes is v then

(6) $|\sigma(I_\omega)| \leq d + r - 2v$.

Now $H_2(W, V) = A \oplus (C \oplus D \oplus E)$ so

(7) $d = \dim A + \dim C + \dim D + \dim E$

and $R_\omega \leq C \oplus D \oplus E$ because $\cdot|A$ is non-singular. Notice that $I_\omega|D \oplus D$

is isometric to $S_{\omega, V, M}$ on $K_V \otimes K_V$, let us identify via $\partial: D \xrightarrow{\cong} K_V$,

then under this identification $R_\omega \leq C \oplus R_{\omega, V, M} \oplus E$ (recall $R_{\omega, V, M}$ is the radical of $S_{\omega, V, M}$). Using (2), (3) (with $R_{\omega, V, M} \leq D$) and (4)

$R_\omega = (C \oplus R_{\omega, V, M}) \cap E^\perp$ and hence

(8) $r = \dim C + \dim R_{\omega, V, M} - \dim E$

As Levine observed, I_ω vanishes on $F = \text{Im}\{H_2(U,V) \longrightarrow H_2(W,V)\}$ because representative cycles are disjoint after translating one of them off U by i_- . However there is a larger subspace on which I_ω vanishes :

$$(C \oplus R_{\omega,V,M}) + \ker\{F \xrightarrow{\partial} H_1(V) \xrightarrow{j} H_1(M)\}$$

{If $r \in R_{\omega,V,M}$ $k \in \ker j\partial$ then $I_\omega(r,k) = S_{\omega,V,M}(\partial r, \partial k) = 0$ because ∂r is in the radical {identifications !} , and $k \cdot C = 0$ because $C = \text{Radical}(\cdot | H_2(W))$ and $k \in \text{Im}\{H_2(W) \longrightarrow H_2(W,V)\}$ }

The dimension of this subspace is

$$(9) \quad v \geq \dim C + \dim R_{\omega,V,M} + \text{nullity}\{i_*: K_V/R_{\omega,V,M} \longrightarrow H_1(U)/i_*R_{\omega,V,M}\}$$

to see this choose $F_1 \leq F$ such that $\partial: F_1 \xrightarrow{\cong} \partial(F) \leq H_1(V)$. Then

$$\partial: \ker\{j\partial|_{F_1}\} \xrightarrow{\cong} \ker\{\text{incl}_*: K_V \longrightarrow H_1(U)\} \quad (\text{recall } K_V = \ker\{H_1(V) \longrightarrow H_1(M)\})$$

so $\dim(C \oplus R_{\omega,V,M}) \cap \ker\{j\partial|_{F_1}\} \leq \dim \partial(C \oplus R_{\omega,V,M}) \cap \partial(\ker j\partial|_{F_1})$

$$\partial(C \oplus R_{\omega,V,M}) \cap \partial \ker j\partial|_{F_1}$$

the term on the right

$$= \partial R_{\omega,V,M} \cap \partial \ker j\partial|_{F_1}$$

because $\partial C = 0$

$$= \ker\{\text{incl}_*: K_V \longrightarrow H_1(U)\} \cap R_{\omega,V,M}$$

identifying $\partial R_{\omega,V,M} = R_{\omega,V,M}$

$$= \ker\{\text{incl}_*: R_{\omega,V,M} \longrightarrow H_1(U)\}$$

and so $\ker j\partial|_{F_1} / (\partial(C \oplus R_{\omega,V,M}) \cap \ker j\partial|_{F_1})$

$$\geq \frac{\ker\{\text{incl}_*: K_V \longrightarrow H_1(U)\}}{\ker\{\text{incl}_*: R_{\omega,V,M} \longrightarrow H_1(U)\}}$$

$$\cong \ker\{i_*: K_V/R_{\omega,V,M} \longrightarrow H_1(U)/i_*R_{\omega,V,M}\}$$

establishing (9). Putting (7), (8) and (9) into (6) gives

$$|\sigma(I_\omega)| \leq \dim A + \dim D - \dim R_{\omega,V,M} - 2\text{nullity}\{i_*: K_V/R_{\omega,V,M} \longrightarrow H_1(U)/i_*R_{\omega,V,M}\}$$

now $\dim A = \text{rk}(\cdot | H_2(W))$ and $\dim D = \dim K_V$ so $\dim K_V/R_{\omega,V,M} = \dim D - \dim R_{\omega,V,M}$, establishing the first part of the theorem.

Let $a = \dim\{\text{Im } H_1(V) \longrightarrow H_1(M) \cap \ker H_1(M) \longrightarrow H_1(W)\}$ then

$$\text{nullity}\{K_V \longrightarrow H_1(U)\} \geq \text{nullity}\{H_1(V) \longrightarrow H_1(U)\} - a$$

$$= \frac{1}{2}\beta_1(V) - a \quad \text{by duality in } U \text{ (recall } \partial U = V)$$

Therefore

$$\begin{aligned} & \dim K_V/R_{\omega, V, M} - 2\text{nullity}\{K_V/R_{\omega, V, M} \xrightarrow{\quad} H_1(U)/i_*R_{\omega, V, M}\} \\ & \leq \dim K_V - \beta_1(V) + 2a + \dim R_{\omega, V, M} \\ & \leq \beta_1(V) - \dim K_V/R_{\omega, V, M} \quad \text{since } a \leq \beta_1(V) - \dim K_V \quad (\Rightarrow 2^{\text{nd}} \text{ bound}) \end{aligned}$$

$$\begin{aligned} \text{By duality in } W \quad \beta_2(W) &= \text{rk}(\cdot | H_2(W)) + \text{nullity}\{H_1(\partial W) \longrightarrow H_1(W)\} \\ &\geq \text{rk}(\cdot | H_2(W)) + a \end{aligned}$$

this last because $a \leq \text{nullity}\{H_1(\partial W) \longrightarrow H_1(W)\}$.

Finally by the radical lemma (2.5) except for finitely many ω
 $\dim R_{\omega, V, M} \leq \dim J_V \leq \beta_1(M)$, giving the third bound, and completing
the proof.

2.11 Definition

A Seifert form on a closed surface is non-singular if for all ω except a finite number of ω , $R_{\omega, V, M} = 0$. Most of the examples are non-singular.

2.12 Remark

The hypotheses of the theorem are equivalent to $\{V\} = 0 \in H_2(W; \mathbb{Z})$
If $K_V = H_1(V)$ and the Seifert form is non-singular, then the bound in
the theorem is $\text{rk}(\cdot | H_2(W))$ which, as will be seen, is sharp.

2.13 Examples

1) Let k be the right hand trefoil knot, and suppose $M(k) = \partial W$ and
 $i_*: H_2(M(k)) \longrightarrow H_2(W)$ is zero. Then either

$$(i) \quad \text{rk}(\cdot | H_2(W)) > 1$$

$$\text{or } (ii) \quad \sigma(W) = +1$$

This is an immediate consequence of the Signature theorem. However there
is an embedding of $M(k)$ into $-CP^2$ such that the closure of one of the
components, W say, of $(-CP^2) - M(k)$ has $\partial W = -M(k)$, $\text{rk}(\cdot | H_2(W)) = 1$,
 $\sigma(W) = -1$ and i_* zero.

2) Let $W_1 = \text{cl}(S^2 \times S^2 - B^4)$, it is well known that any knot k in $S^3 = \partial W_1$ is slice (ie bounds a smooth disc) in W_1 . Briefly k may be changed into the unknot by changing crossovers; instead of changing a crossover do a band move (chap 2, sec5) round the crossover as in (i)

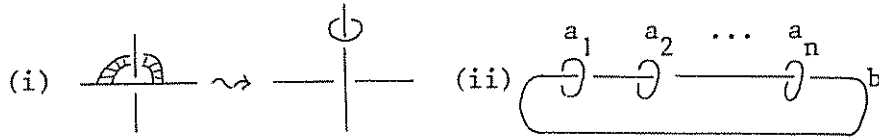

The end result is a link as shown in (ii), the components of which bound disjoint smooth discs in W_1 . It follows that k bounds a disk D smoothly embedded in W_1 . Then $\text{framing}(\partial D) = 2 \sum \text{Lk}(a_i, b)$. Any even framing can be obtained by altering the presentation of k and doing extra band moves thus:

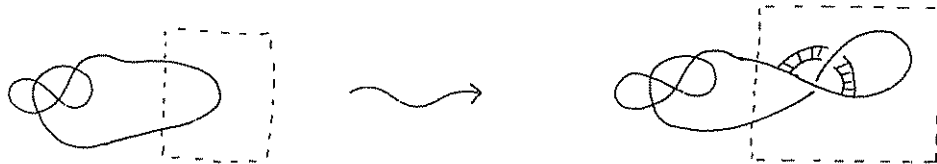

It follows that $M(k)$ embeds in $S^2 \times S^2$ for every k , however i_x is not usually zero.

2.14 Example

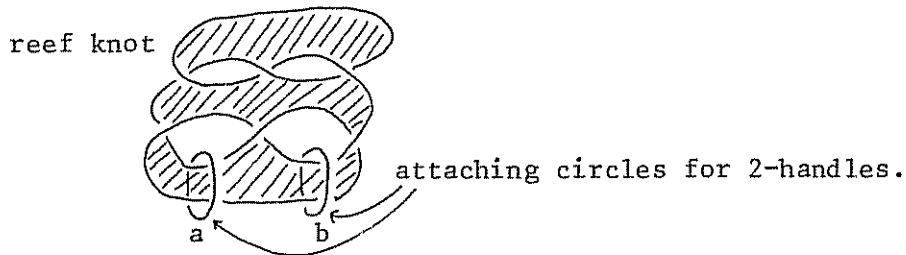

Let k be the reef knot (=sum of right hand + left hand trefoil) and $M(k)$ as described in example 2 of (2.2). The reef knot is slice in S^3 so $\sigma(\omega, k) = 0$. Let V be the surface in $M(k)$ formed by a Seifert surface for k + core of handle. From B^4 remove a neighbourhood of a slice disc for the reef knot, and call the resulting manifold W_1 , then $\partial W_1 = M(k)$ and the Signature theorem says ' $0 \leq 0$ '. Now attach two 2-handles to W_1 with framing zero using the circles marked a and b in the diagram, call the resulting manifold W , and $M = \partial W$. Then the surface V above lies in M and $\sigma(\omega, V, M) = \sigma(\omega, \text{left hand trefoil}) = +2$ if $\omega = -1$, $K_V = 2\mathbb{Z}$, $\beta_1(V) = 4\mathbb{Z}$, $\text{rk}(\cdot | H_2(W)) = 0$. It is seen that the theorem holds with equality and that the bound cannot be replaced by $\text{rk}(\cdot | H_2(W))$.

2.15 Corollary 1

Suppose (W^4, M_1, M_2) is a compact homology cobordism, then $\partial W = M_1 \cup M_2$ and this determines an isomorphism $f: H_*^x(M_1) \rightarrow H_*^x(M_2)$. If V_i is a closed surface in M_i , for $i=1,2$ and $f\{V_1\}=\{V_2\} \in H_2(M_2)$ and if the Seifert forms for V_1 and V_2 are non-singular, then

$$\tau(\omega, V_1, M_1) = -\tau(\omega, V_2, M_2)$$

Proof: The hypotheses (+ transversality) give a 3-manifold U properly embedded in W with $\partial U \cap M_i = V_i$. Apply the Signature theorem to $(M, V) = \partial(W, U)$ then $\sigma(\omega, V, M) = \sigma(\omega, V_1, M_1) + \sigma(\omega, V_2, M_2)$. The homology cobordism hypothesis implies $\text{rk}(\cdot | H_2(W)) = 0$, and that

$$\begin{aligned} & \text{nullity}\{K_V \rightarrow H_1(U)\} \\ & \geq \frac{1}{2}\beta_1(V) - \min_i \{\text{rk } H_1(V_i) \rightarrow H_1(M_i)\} \\ & = \frac{1}{2}\beta_1(V) - \min_i \{\beta_1(V_i) - \dim K_{V_i}\} \end{aligned}$$

The bound in the Signature theorem is accordingly

$$\sum_i \dim K_{V_i} - 2\left\{\frac{1}{2}\sum_i \beta_1(V_i) - \min_i (\beta_1(V_i) - \dim K_{V_i})\right\}$$

which can only be non-negative if $\beta_1(V_1) - \dim K_{V_1} = \beta_1(V_2) - \dim K_{V_2}$

It follows that $|\tau(\omega, V_1, M_1) + \tau(\omega, V_2, M_2)| = 0$, except for finitely many ω , and so by the limit definition of τ , this holds for all ω , completing the proof.

Example

The manifold M constructed in example (2.14) is not homology cobordant to $M_1 = M(K) \# 2S^1 \times S^2$ where K is the reef knot, for it is easy to show that any surface in M_1 has zero signature.

2.16 Corollary 2

If V_1 and V_2 are two surfaces in M , without boundary, and if $\{V_1\} = \{V_2\} \in H_2(M)$ and if the Seifert forms are non-singular then

$$\tau(\omega, V_1, M_1) = \tau(\omega, V_2, M_2)$$

Proof: apply the preceding corollary to (M, V_1) and $-(M, V_2)$ with $W = M \times I$, noting that $\tau(\omega, -V_2, -M_2) = \tau(\omega, V_2, -M_2) = -\tau(\omega, V_2, M_2)$ completing the proof.

2.17 Corollary 3

Given $n \geq 0$ there is a closed 3-manifold M which does not embed in any closed oriented 4-manifold W in which $\beta_1(W)=0$ and $\beta_2(W) < n$.

Proof: Let k be the knot in S^3 which is the connected sum of n (right hand) trefoil knots, and define M to be the connected sum of n copies of $M(k)$. Then $H_2(M)$ has a basis represented by surfaces V_i each lying in one of the copies of $M(k)$ in the connected sum. If V is any surface in M $\{V\} = \sum n_i \{V_i\} \in H_2(M)$ then the signature of V (being an invariant of the homology class) is

$$\begin{aligned} \sigma(\omega, V, M) &= \sum \sigma(\omega, n_i V_i, M(k)) && \text{(justified by 2.19)} \\ &= \sum \sigma(\omega, |n_i|, V_i, M(k)) && \text{by 2.26} \end{aligned}$$

From (2.2) example 1 we have that $\sigma(e^{i\theta}, V_i, M(k)) = -2n$ for $\pi/6 < \theta < 11\pi/6$, so if any n_i is non-zero there are ω with $|\sigma(\omega, V, M)| \geq 2n$.

Now suppose M embeds in W , then M separates W into two components W_1 and W_2 because $\beta_1(W)=0$. A Mayer Vietoris argument implies that $H_2(M) \rightarrow H_2(W_i)$ can not be injective for both $i=1,2$. Suppose not injective for $i=1$, then $\partial W_1 = \pm M$ (the sign depending on the orientation induced by W_1). There is a surface V in M with $\{V\} \neq 0 \in H_2(M)$ but which bounds in W_1 , so the Signature theorem gives :

$|\sigma(\omega, V, M)| \leq |\sigma(W)| + \text{rk}(\cdot | H_2(W_1))$ (the other terms are zero because $K_V = H_1(V)$ and the Seifert form is non-singular) which is less than $2n$, giving a contradiction which establishes the result.

2.18 Remark

The idea exploited in the next two results is that if $a \in Z_2(M, \partial M)$ and β represents a class in K_V then $a \cdot \beta = 0$. This has the consequence that if a surface V is contained in ∂M then $\sigma(\omega, V, M) = 0$. Another consequence is that if $I \times D^2$ is attached along $I \times \partial D^2$ to ∂M creating M_1 such that ∂D is a component, C say, of ∂V then $\sigma(\omega, V, M) = \sigma(\omega, V, M_1)$. Furthermore, if D is attached to V along C to create a surface V_1 then $\sigma(\omega, V_1, M_1) = \sigma(\omega, V, M)$.

2.19 First Additivity Theorem

Suppose V_1 is a surface properly embedded in $\text{cl}(M_1 - I \times \partial M_1)$ and V_2 is properly embedded in M_2 . Suppose also that T is a surface (possibly with boundary) lying in ∂M_1 and ϕ is an orientation reversing embedding of T into ∂M_2 . Let $(M, V) = (M_1, V_1) \cup (M_2, V_2)$ joined by ϕ , then

$$|\sigma(\omega, V, M) - \sigma(\omega, V_1, M_1) - \sigma(\omega, V_2, M_2)| \leq \text{rk}\{i_1^*: H^1(M - V, \partial M) \rightarrow H^1(T)\} - \text{rk}\{i_2^*: H^1(M - \partial V, \partial M) \rightarrow H^1(T)\}$$

where i_1^* and i_2^* are restrictions.

Proof: V_1 and V_2 are disjoint, so the Mayer Vietoris sequence for (M_1, V_1) and (M_2, V_2) is

$$\rightarrow H_2(T) \xrightarrow{k} H_2(M_1, V_1) \oplus H_2(M_2, V_2) \xrightarrow{\ell} H_2(M, V) \xrightarrow{\Delta} H_1(T) \rightarrow$$

1) by exactness ℓ induces an isometry

$$I_{\omega, V_1, M_1} \oplus I_{\omega, V_2, M_2} \xrightarrow{\quad} I_{\omega, V, M} \Big|_{\text{Im } \ell} \oplus O_{\text{Im } k}$$

where $O_{\text{Im } k}$ is the zero form on the space $\text{Im } k$.

2) Let $j: H_2(M, \partial V) \rightarrow H_2(M, V)$ be induced by inclusion, then

$I_{\omega, V, M}$ vanishes on $\text{Im } j \oplus \text{Im } \ell$. For if $a \in Z_2(M, \partial V)$ $b_i \in Z_2(M_i, V_i)$

then $I_{V, M}(a, b_1 + b_2) = \partial a \cdot (b_1 + b_2) \quad \cdot \text{ in } M$

now $\partial a = \alpha_1 + \alpha_2$ where $\alpha_i \in Z_1(\partial V_i)$ and $\partial a \cdot (b_1 + b_2) = \alpha_1 \cdot b_1 + \alpha_2 \cdot b_2$

but by (2.18) $\alpha_i \cdot b_i = 0$ using the hypothesis on V_1 .

Define $A = \text{Im } \ell + \text{Im } j$ then 1 and 2 show there is an isometry between $I_{\omega, V, M} \upharpoonright^A \oplus O_{\text{Im } k}$ and $I_{\omega, V_1, M_1} \oplus I_{\omega, V_2, M_2} \oplus O_{\text{Im } \Delta j}$

Observe that if h is an Hermitian form defined on a space $W = W_1 \oplus W_2$

then $|\sigma(h) - \sigma(h|_{W_1})| \leq \dim W_2$. Our situation is $h = I_{\omega, V, M}$, $W = H_2(M, V)$

and $W_1 = A$, so

$$|\sigma(\omega, V, M) - \sigma(\omega, V_1, M_1) - \sigma(\omega, V_2, M_2)| \leq \dim H_2(M, V) - \dim A$$

by exactness $\dim H_2(M, V) = \text{rk } \ell + \text{rk } \Delta$

$$\text{and } \dim A = \text{rk } \ell + \text{rk } \Delta j$$

By Alexander duality, $H_2(M, V) \cong H^1(M - V, \partial M)$

and $\text{rk } \Delta = \text{rk}\{i_1^*: H^1(M - V, \partial M) \rightarrow H^1(T)\}$

Similarly $H_2(M, \partial V) \cong H^1(M - \partial V, \partial M)$

and $\text{rk } \Delta j = \text{rk}\{i_2^*: H^1(M - \partial V, \partial M) \rightarrow H^1(T)\}$ completing the proof.

2.20 Second Additivity Theorem

Suppose given the hypotheses of the preceding theorem, except that now V_1 is properly embedded in M_1 :

Suppose also that

any component of ∂V_1 which meets T lies entirely in T and that

$\phi(T \cap \partial V_1) = \phi(T) \cap \partial(-V_2)$. Let $(M, V) = (M_1, V_1) \cup (M_2, V_2)$ joined along

$(T, T \cap V_1)$ by ϕ . Then

$$\begin{aligned} & |\tau(\omega, V, M) - \tau(\omega, V_1, M_1) - \tau(\omega, V_2, M_2)| \\ & \leq \text{rk}\{i_1^*: H^1(M - V', \partial M) \rightarrow H^1(T)\} - \text{rk}\{i_2^*: H^1(M - \partial V, \partial M) \rightarrow H^1(T)\} \\ & \quad + \text{rk}\{\cdot |_{K_V} \otimes H_1(T \cap V)\} - \text{rk}\{\cdot |_{K_V} \otimes \ker\{H_1(T \cap V) \rightarrow H_1(\partial M_1)\}\} \end{aligned}$$

$$\leq \beta_1(T)$$

where \cdot is the intersection pairing on $H_1(V)$ and $V' = V - (T \cap V)$

Proof: Let $V'_1 = V_1 - (V_1 \cap \partial M_1 \times I)$ and $V' = V'_1 \cup V_2$ then we are in the situation of the preceding theorem. Consider :

$$H_2(M, V') \xrightarrow{i_*} H_2(M, V) \xrightarrow{\delta} H_0(V \cap T)$$

where δ is the composite

$$\begin{array}{ccc} H_2(M, V) & \xrightarrow{\partial} & H_1(V) & \text{boundary homomorphism of the pair} \\ H_1(V) & \xrightarrow{\delta^1} & H_0(V \cap T) & \text{boundary homomorphism of Mayer} \\ & & & \text{Vietoris sequence of } V_1 \text{ and } V_2 \end{array}$$

then it is clear that $\text{Im } i_* = \ker \delta$. Consider the map induced by

inclusion $k_*: H_2(\partial M_1, V \cap T) \rightarrow H_2(M, V)$ then $I_{\omega, V, M}$ vanishes on

$\text{Im } k_* \oplus \text{Im } i_*$ because if $\{a\} \in \text{Im } k_*$ $\{b\} \in \text{Im } i_*$ then $b \in Z_2(M, V')$

may be chosen so that $\partial b \in B_1(\text{int } V')$ by pushing ∂b in along a collar of V' in V . Then ∂b is disjoint from ∂M_1 and so from $a \in Z_2(\partial M_1, V \cap T)$.

Notice that $\text{Im } k_* \leq \text{Im } i_*$, so that $\text{Im } k_* \leq \text{Radical}(I_{\omega, V, M} | \text{Im } i_*)$.

Choose $A \leq H_2(M, V)$ such that $H_2(M, V) = A \oplus \text{Im } i_*$ and define $B \leq A$

by $B = A \cap \partial^{-1}(\partial \text{Im } k_*)^\perp$ where \perp is with respect to \cdot on $H_1(V)$.

Choose $C \leq A$ such that $A = B \oplus C$, we will prove that

$$1) \quad \sigma(I_{\omega, V, M} | \text{Im } i_* \oplus C) = \sigma(I_{\omega, V, M} | \text{Im } i_*) \quad \text{except for finitely many } \omega$$

Choose a basis $\{k_1, \dots, k_s\}$ of $\text{Im } k_*$ and a basis $\{c_1, \dots, c_t\}$ of C

($t \leq s$) such that $c_i \cdot k_j = \delta_{ij}$ \cdot on $H_1(V)$.

Define a $t \times t$ matrix B by $B_{ij} = S_{V, M}(k_i, c_j)$ then $B_{ij} = B_{ji} + \delta_{ij}$

Choose a basis of $(\text{Im } i_* \oplus C)$ $\{v_1, \dots, v_n\}$ with

$$\begin{aligned} v_i &= k_i & \text{for } 1 \leq i \leq t \\ &= c_i & \text{for } t+1 \leq i \leq 2t \end{aligned}$$

and let A be the $n \times n$ matrix of $S_{V, M}$ using this basis. The matrix $A - tA'$

is

$$\begin{bmatrix} 0 & B(1-t) + tI & 0 \\ B'(1-t) + I & \begin{array}{c} \hline * \\ \hline \end{array} & \\ 0 & \begin{array}{c} \hline \hline \\ \hline \end{array} & B_1(t) \end{bmatrix}$$

define $f(t) = \det(B(1-t) + tI)$, then $f(1) = \pm 1$, hence for all but finitely

many ω , $f(\bar{\omega}) \neq 0$ and

$\sigma((1-\omega)(A-\bar{\omega}A')) = \sigma((1-\omega)B_1(\bar{\omega}))$ proving (1). It follows that

$$|\sigma(I_{\omega,V,M}) - \sigma(I_{\omega,V,M}|_{\text{Im } i_*})| \leq \dim B$$

$$\text{now } \sigma(I_{\omega,V,M}|_{\text{Im } i_*}) = \sigma(I_{\omega,V',M}) = \sigma(\omega,V',M).$$

The hypothesis that every component of ∂V_1 which meets T lies entirely in T ensures that under \cdot on $H_1(V)$, $B + C$ is non-singularly paired into $H_1(V \cap T)$. Hence

$$\dim B+C = \text{rk}(\cdot|_{K_V} \otimes H_1(T \cap V))$$

$$\text{and } \dim C = \text{rk}(\cdot|_{K_V} \otimes \partial \text{Im } k_*)$$

$$\text{now } \partial \text{Im } k_* = \ker\{H_1(V \cap T) \longrightarrow H_1(\partial M_1)\}$$

which together with the previous theorem gives the result for all but finitely many ω , and as in (2.15) this implies the result for all ω .

Using the definition of Δ, j from the previous proof,

$$(2) \quad \text{Im } \Delta j \geq \text{Im}\{H_1(T \cap V) \longrightarrow H_1(T)\}$$

{if $\alpha \in Z_1(T \cap V)$ then $Ix\alpha \in H_2(M, \partial V')$ } hence

$$\text{rk } i_2^*$$

$$= \text{rk } \Delta j$$

$$\geq \text{rk}\{H_1(T \cap V) \longrightarrow H_1(T)\} \quad \text{by (2)}$$

$$\geq \text{rk}\{H_1(T \cap V) \longrightarrow H_1(\partial M_1)\} = a \quad \text{say}$$

$$\text{clearly } \text{rk}\{\cdot|_{K_V} \otimes H_1(T \cap V)\} - \text{rk}\{\cdot|_{K_V} \otimes \ker\{H_1(T \cap V) \longrightarrow H_1(\partial M_1)\}\}$$

$$\leq a$$

so the bound does not exceed $\text{rk } i_1^* \leq \beta_1(T)$, completing the proof.

2.21 Remark

The careful reader may now verify the remarks in (2.18).

2.22 Examples

1) If M is the connected sum of M_1 and M_2 and V_i is a surface in M_i which misses the ball removed from M_i for the connected sum, then (M_1 -ball) is joined to (M_2 -ball) along a 2-sphere, so all the terms in the bounds vanish giving

$$\sigma(\omega, V_1 \cup V_2, M) = \sigma(\omega, V_1, M_1) + \sigma(\omega, V_2, M_2)$$

whether or not ∂V_1 is joined to ∂V_2 .

2) Let k_i be a knot in S^3 for $i=1,2$ and $M_i = \text{cl}(S^3 - k_i \times B^2)$, and set $M = M_1 \cup M_2$ joined so that longitudes of k_i in M_i are identified. Then $H_2(M) \cong \mathbb{Z}$ and if V is a surface in M formed by joining along ∂V_i Seifert surfaces V_i for k_i properly embedded in M_i , then using the Second theorem, $\text{rk } i_1^* = \text{rk } i_2^* = 1$, and the $\text{rk}(\cdot | \cdot)$ terms are both zero, so

$$\begin{aligned} \sigma(\omega, V, M) &= \sigma(\omega, V_1, M_1) + \sigma(\omega, V_2, M_2) \\ &= \sigma(\omega, k_1) + \sigma(\omega, k_2) \end{aligned}$$

2.23 Proposition

Suppose V, V_1, V_2 are closed oriented surfaces in M , and $\{V\} = n\{V_1\} + \{V_2\} \in H_2(M; \mathbb{Z})$ $n \in \mathbb{Z}$ then :

$$|\tau(\omega, V, M) - \tau(\omega, V_2, M)| \leq 6\beta_1(V_1)$$

This is a rather technical result which will be used to produce a bound on signatures of closed surfaces in manifolds, it is a crude bound which may be compared with the parallel surfaces theorem (2.26).

Proof: If two oriented surfaces V_1 and V_2 meet transversely, they intersect in a 1-manifold and a neighbourhood of a point in the intersection is $I \times \text{fig}(i)$. The surfaces may be cut along the intersection and cross joined, preserving orientation, as shown in $I \times \text{fig}(ii)$

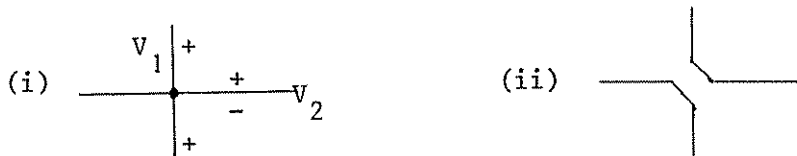

For closed surfaces, σ depends only on the homology class, so we can choose V to be obtained by cutting and cross joining V_2 with n parallel copies of V_1 . Let $N = V_1 \times I$ be a neighbourhood of V_1 in which $V_2 \cap N = (V_2 \cap V_1) \times I$. Define $X = \text{cl}(M - N)$, then by additivity :

$$1) \quad |\tau(\omega, V, M) - \tau(\omega, V \cap N, N) - \tau(\omega, V \cap X, X)| \leq 2\beta_1(V_1)$$

$$2) \quad |\tau(\omega, V_2 \cap M, M) - \tau(\omega, V_2 \cap N, N) - \tau(\omega, V_2 \cap X, X)| \leq 2\beta_1(V_1)$$

now $\tau(\omega, V_2 \cap N, N) = 0$ by (2.18) because $H_1(V_2 \cap \partial N) \longrightarrow H_1(V_2 \cap N)$ is surjective, Note that $V_2 \cap X = V \cap X$.

Write $A = V_2 \cap N$ then $\partial N = V_1 \times 0 \cup V_1 \times 1$ and $A \cap (V_1 \times 0)$ is a number of disjoint circles C_1, \dots, C_r say. If any circle C_i does not bound in $V_1 \times 0$, attach $I \times D_i^2$ along $I \times \partial D_i^2$ to $V_1 \times 0$ such that $\partial D_i = C_i$, and $I \times \partial D_i$ misses the other circles. Then attach D_i to A along C_i , the resulting surface has the same signature as A by (2.18). This process has reduced the genus of ∂N and after repeating at most $\text{genus}(V_1)$ times the remaining circles all bound in the boundary of the new manifold.

Choose a circle innermost on this boundary, and cap off the circle using that part of the boundary it bounds which does not contain any other circles. This process does not change τ . Repeat until there are not any circles left. This has created a new surface A_1 say, in a manifold N_1 with $(A, N) \subset (A_1, N_1)$ and $\tau(\omega, A, N) = \tau(\omega, A_1, N_1)$.

Define $\partial_0 N_1 = \partial N_1 - V_1 \times 1$, choose any compact manifold Y with $\partial Y = \partial_0 N_1$ and set $N_2 = Y \cup N_1$ identifying ∂Y with $\partial_0 N_1$ by any homeomorphism.

Then by additivity:

$$|\tau(\omega, A_1, N_2) - \tau(\omega, A_1, N_1)| \leq \beta_1(\partial_0 N_1) \leq \beta_1(V_1)$$

the point of this is that $\{V_2\} = 0 \in H_2(N_2)$ and so

$$\{A_1\} = \{A_1\} + n\{V_2\} \in H_2(N_2, \partial N_2).$$

Let B be obtained by cutting and cross joining A_1 and n copies of V_2 , so $\{B\} = \{A_1\} \in H_2(N_2, \partial N_2)$ and $\partial B = \partial A_1$, hence

$$\tau(\omega, B, N_2) = \tau(\omega, A_1, N_2).$$

Now $|\tau(\omega, B, N_2) - \tau(\omega, B \cap N, N)| \leq \beta_1(V_1)$ because the process of constructing A_1 and N_1 from A also produces B and N_1 from $B \cap N$ because $\partial(B \cap N) = \partial(A \cap N)$.

But $B \cap N = V \cap N$ and so :

$$3) \quad |\tau(\omega, V \cap N, N) - \tau(\omega, V_2 \cap N, N)| \leq 2\beta_1(V_1)$$

and $\tau(\omega, V_2 \cap N, N) = 0$ as noted earlier. Putting 1, 2 and 3 together completes the proof.

The Finiteness conjecture

We can now prove a finiteness result which will be needed in the analysis of slice knots in section 3. The hypothesis in the theorem on ∂M ought to be unnecessary (I conjecture), using additivity this is equivalent to requiring finiteness for handlebodies, which is in turn equivalent to asking for a bound (depending only on g) on the signatures of any link in S^3 which lies on the surface of the standard handlebody of genus g in S^3 , and bounds a surface inside that handlebody.

2.24 Finiteness Theorem

If M is a compact oriented manifold and $\beta_1(\partial M) \leq 2$, then there is a positive integer K such that for all surfaces V properly embedded in M $|\tau(\omega, V, M)| \leq K$ for all ω .

Proof: Suppose first that M is closed, then $H_2(M; \mathbb{Z})$ is finitely generated because M is compact, Choose closed surfaces V_1, \dots, V_n representing a basis, then repeated application of the preceding proposition gives a bound of $6 \sum \beta_1(V_i)$.

Return now to the general case, ∂M consists of a number of spheres and at most one torus T . A properly embedded surface in M meets each 2-sphere in a number of circles. Join a 3-ball to each sphere, and join discs in the 3-ball onto the components of ∂V in each sphere. By additivity this doesn't change τ . We are left with $\partial M = T$, ∂V is a number of circles in T . If any circle bounds a disc in T , an innermost one bounds a disc in T disjoint from V , and so these circles may be capped off by discs

in M without changing τ . Thus every component of ∂V is non-zero in $H_1(T)$ therefore they must all be parallel (after an isotopy). By duality $\ker\{H_1(T) \rightarrow H_1(M)\} \cong \mathbb{Z}$, so join a solid torus S to M along T such that $\ker\{H_1(T) \rightarrow H_1(S)\} = \ker\{H_1(T) \rightarrow H_1(M)\}$. Then there is a surface V' in S with $\partial V' = \partial V$. If we can show finiteness in S , that for M will follow by additivity. $\partial V'$ is a number of parallel circles in ∂S , either each circle $= 0 \in H_1(S)$, in which case V' may be chosen as a number of parallel discs (so $\tau = 0$), or else $\{V'\} = 0 \in H_1(S)$, so that $V' = n\alpha + n(-\alpha)$ where α is a component of $\partial V'$, n a positive integer and $-\alpha$ is the parallel circle oppositely oriented. In this case, V' may be chosen to be a number of annuli, each annulus having boundary $\alpha + (-\alpha)$. It is clear that $\tau = 0$ in this case also, thus proving finiteness for S and hence for M .

2.25 Remark

The condition that V be properly embedded in M is necessary because there are knots in S^3 having arbitrarily large signature.

The parallel surfaces theorem below is best proved by using the connection with G -signatures (see 4.4), however an elementary proof is given here.

2.26 Parallel Surfaces Theorem

Let V be a surface in M , n an integer, and let nV denote n parallel copies of V (if $n < 0$ then V has the opposite orientation).

Then
$$\tau(\omega, nV, M) = \tau(\omega \upharpoonright_{nV}, V, M)$$

This is a well known result for knot signatures, eg see (Li).

Proof: Since $\tau(\omega, -V, M) = \tau(\omega, V, M)$, it suffices to prove the result when $n \geq 0$. Let V_1, \dots, V_n be the n parallel copies of V and i_r the map induced by identification on $H_1(V_1) \rightarrow H_1(V_r)$. Then

$$\ker\{H_1(nV) \rightarrow H_1(M)\} = \ker\{H_1(V_1) \rightarrow H_1(M)\} \oplus \bigoplus_{r=1}^{n-1} \text{Im}(i_{r+1} - i_r)$$

Choose a basis of $\ker\{H_1(V_1) \rightarrow H_1(M)\}$ and extend to a basis of $H_1(V_1)$. Choose the basis of $\text{Im}(i_{r+1}^{-1}i_r)$ obtained by applying $(i_{r+1}^{-1}i_r)$ to the basis of $H_1(V_1)$. Let A be the matrix of the Seifert form $S_{V_1, M}$ and D the matrix of $S_{V, M}|_{\text{Im}(i_{r+1}^{-1}i_r) \otimes \text{Im}(i_{r+1}^{-1}i_r)}$. Then D is the matrix of the intersection pairing on $H_1(V_1)$ using the chosen basis (2-chains bounding cycles are annuli between V_{r+1} and V_r) so $D' = -D$.

Also, writing $D_1 = A - A'$, then

$$D = \begin{bmatrix} D_1 & -D'_2 \\ D_2 & D_3 \end{bmatrix}$$

The matrix of $S_{nV, M}$ using the above basis is:

$$M = \begin{bmatrix} A & \text{---} 0 \text{---} \\ -D_1 & \begin{array}{c} \boxed{D} \\ -D \quad D \quad \cdot \\ \cdot \quad \cdot \quad \cdot \\ \cdot \quad \cdot \quad \cdot \\ -D \quad D \end{array} \\ -D_2 & \\ \vdots & \\ 0 & \\ \vdots & \end{bmatrix} \quad \begin{array}{l} \uparrow \\ n-1 \text{ rows of } D \\ \downarrow \end{array}$$

Consider the bottom right hand square of $(1-\bar{t})(tM-M')$, it is:

$$\begin{array}{c} \uparrow \\ n-1 \text{ rows} \\ \downarrow \end{array} \begin{bmatrix} (t-\bar{t})D & (\bar{t}-1)D & & & \\ (1-t)D & (t-\bar{t})D & (\bar{t}-1)D & & \\ & (1-t)D & (t-\bar{t})D & \cdot & \\ & & \cdot & \cdot & (\bar{t}-1)D \\ & & & \cdot & \\ & & & (1-t)D & (t-\bar{t})D \end{bmatrix}$$

Define $\lambda_r = \frac{(t-1)(t^{r+1}-1)}{t(t^r-1)}$ so $\lambda_r = -\bar{\lambda}_r$ and $\lambda_1 = t - \bar{t}$

$$\text{if } P = \begin{bmatrix} 1 & (1-\bar{t})/\lambda_r \\ 0 & 1 \end{bmatrix} \text{ then } P \begin{bmatrix} (t-\bar{t}) & (\bar{t}-1) \\ (1-t) & \lambda_r \end{bmatrix} P^\dagger = \begin{bmatrix} \lambda_{r+1} & 0 \\ 0 & \lambda_r \end{bmatrix}$$

therefore the above matrix is congruent to :

§3 Slice Knots

As a first application, the process of producing algebraically slice knots outlined in the introduction is applied to the (slice) knot 8_{20} in the table of Alexander and Briggs, see (R). This knot has an algebraic feature which enables a proof that certain related knots are not ribbon, based only on the Signature theorem (finiteness is not used). An additional reason for studying this knot is that the geometry is particularly simple. An improved finiteness theorem is needed in order to prove these same knots are not slice.

3.1 Definition

A knot k in S^3 is ribbon if k bounds a disc immersed in S^3 the self intersections of which are ribbon, ie have a neighbourhood like:

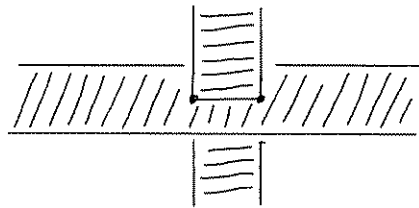

clearly a ribbon knot is slice {see (R) p 225 }

Notation

In this section :

k	is a slice knot in S^3
V	is a Seifert surface for k
M	is obtained by 0-surgery along k in S^3
D	is a slice disc for k in B^4
W	is $cl(B^4 - \text{regular neighbourhood of } D)$
\tilde{M}_n	for $n \in \mathbb{Z}$ or $n = \infty$ is the n -fold cyclic cover of M
\tilde{M}_n^{br}	for $n \in \mathbb{Z}$ is the n -fold cover of S^3 branched over k .
\tilde{W}_n	for $n \in \mathbb{Z}$ or $n = \infty$ is the n -fold cyclic cover of W
\tilde{W}_n^{br}	for $n \in \mathbb{Z}$ is the n -fold cover of B^4 branched over D
Λ	$= \mathbb{Q}[t, t^{-1}]$ where t generates the group of covering automorphisms of \tilde{M}_∞

then $\partial W = M$, $\partial \tilde{W}_n = \tilde{M}_n$, $\partial \tilde{W}_n^{br} = \tilde{M}_n^{br}$.

For a ribbon knot, $i_*: \pi_1(M) \longrightarrow \pi_1(W)$ is surjective [(CG) lemma 1, (T)]
it follows that $i_*: \pi_1''(M)/\pi_1'(M) \longrightarrow \pi_1''(W)/\pi_1'(W)$ is surjective, hence

3.2 Proposition

If k is ribbon, and \tilde{W}_∞ is constructed using a ribbon disc D , then

$$i_*: H_1(\tilde{M}_\infty) \longrightarrow H_1(\tilde{W}_\infty) \quad \text{is surjective.}$$

According to Milnor (Mil) \tilde{W}_∞ has the rational cohomology properties of a 3-manifold $\times \mathbb{R}$, in fact

3.3 Proposition

If k is a slice knot, F a field, then $H_*(\tilde{M}_\infty; F)$ and $H_*(\tilde{W}_\infty; F)$ are finite dimensional, and:

$$2\text{nullity}\{i_*: H_1(\tilde{M}_\infty; F) \longrightarrow H_1(\tilde{W}_\infty; F)\} = \beta_1(\tilde{M}_\infty; F)$$

from the same paper, we extract the following result:

3.4 Proposition

If $p: \tilde{X} \longrightarrow X$ is an infinite cyclic covering of a finite complex, t a generator of the group of covering automorphisms, then there is an exact sequence, with coefficients in any ring ,

$$\rightarrow H_n(\tilde{X}) \xrightarrow{t_* - 1} H_n(\tilde{X}) \xrightarrow{p_*} H_n(X) \xrightarrow{\partial} H_{n-1}(\tilde{X}) \rightarrow$$

3.5 Definition

For a knot k , a Slice Submodule is a submodule of $H_1(\tilde{M}_\infty; \mathbb{Q})$ as a Λ -module of half dimension as a \mathbb{Q} -vector space. If k is a slice knot then $\ker\{i_*: H_1(\tilde{M}_\infty) \longrightarrow H_1(\tilde{W}_\infty)\}$ is a slice submodule by (3.3). In general there may be many slice submodules, (though the choice can be

reduced by adding to the definition the requirement that the Blanchfield pairing (Bla) vanish on a slice submodule).

3.6 The Knot 8_{20}

The knot 8_{20} is shown in fig(3.1), $H_1(\tilde{M}_\infty)$ is a cyclic Λ -module of order $\{f(t)\}^2$ where $f(t)$ is the cyclotomic polynomial (t^2-t+1) . Thus there is a unique slice submodule, $f(t)H_1(\tilde{M}_\infty)$. According to Summers (Sum) or (G p 16), if $H_1(\tilde{M}_\infty; \mathbb{Q}) = \bigoplus_{i=1}^n \Lambda / \langle f_i \rangle$ then $\dim_{\mathbb{C}} H_1(\tilde{M}_k^{br}; \mathbb{C}) = \sum_{i=1}^n n_i$ where n_i is the number of distinct k 'th roots of unity which are zeroes of f_i . Thus $H_1(\tilde{M}_{6n}^{br}; \mathbb{C}) \cong 2\mathbb{C}$ (for 8_{20} this fact is easily established from a presentation of $H_1(\tilde{M}_\infty)$ using a Seifert matrix). By Universal coefficients, $H_1(\tilde{M}_{6n}^{br}; \mathbb{Q}) \cong 2\mathbb{Q}$, and it must follow that:

$$\ker\{p_*: H_1(\tilde{M}_\infty; \mathbb{Q}) \rightarrow H_1(\tilde{M}_{6n}^{br}; \mathbb{Q})\} = f(t)H_1(\tilde{M}_\infty; \mathbb{Q})$$

$$(p_*: H_1(\tilde{M}_\infty) \xrightarrow{\text{proj}_*} H_1(\tilde{M}_{6n}) \xleftarrow{\cong} H_1(\tilde{M}_{6n} \cap \tilde{M}_{6n}^{br}) \xrightarrow{\text{incl}_*} H_1(\tilde{M}_{6n}^{br}))$$

) Consider now any knot with the above module structure, and suppose D is a ribbon disc for k . Then constructing W from D , there is a commutative diagram (coefficients \mathbb{Q})

$$\begin{array}{ccc} H_1(\tilde{M}_\infty) & \xrightarrow{i_*} & H_1(\tilde{W}_\infty) \\ p_* \downarrow & & \downarrow p_*^1 \\ H_1(\tilde{M}_{6n}^{br}) & \xrightarrow{i_*^1} & H_1(\tilde{W}_{6n}^{br}) \end{array}$$

by (3.2) i_* is surjective, and by (3.3) $H_1(\tilde{W}_\infty) \cong f(t)H_1(\tilde{M}_\infty)$. Hence $\ker i_* = \ker p_*$. Now

$$\begin{aligned} H_1(\tilde{W}_{6n}^{br}) &\cong H_1(\tilde{W}_\infty) / \langle t^{6n-1} \rangle && \text{eg by (3.4)} \\ &\cong \Lambda / \langle f(t), t^{6n-1} \rangle \\ &\cong H_1(\tilde{W}_\infty) && \text{because } f(t) \mid t^{6n-1} \end{aligned}$$

Thus p_*^1 is an isomorphism, and by commutivity, i_*^1 is an isomorphism.

3.7 Remark

There is a slice disc for 8_{20} such that i_*^1 is identically zero. This is why the technique wont prove not slice, only not ribbon. In other words, (3.2) is essential here.

Duality in \tilde{W}_{6n}^{br} now implies that $i_*: H_2(\tilde{M}_{6n}^{br}; \mathbb{Q}) \longrightarrow H_2(\tilde{W}_{6n}^{br}; \mathbb{Q})$ is identically zero. By Universal coefficients,

$$\text{Im}\{i_*: H_2(\tilde{M}_{6n}^{br}; \mathbb{Z}) \longrightarrow H_2(\tilde{W}_{6n}^{br}; \mathbb{Z})\}$$

is finite, thus given a (closed oriented) surface P say, in \tilde{M}_{6n}^{br} there exists an integer $m > 0$ such that $mi_*\{P\} = 0 \in H_2(\tilde{W}_{6n}^{br}; \mathbb{Z})$. The Signature theorem now implies that :

$$\begin{aligned} |\tau(\omega, mP, \tilde{M}_{6n}^{br}) + \sigma(\tilde{W}_{6n}^{br})| &\leq \beta_2(\tilde{W}_{6n}^{br}) + \beta_1(\tilde{M}_{6n}^{br}) \\ \text{hence } |\tau(\omega^{m|}, P, \tilde{M}_{6n}^{br})| &\leq 2\beta_2(\tilde{W}_{6n}^{br}) + \beta_1(\tilde{M}_{6n}^{br}) \quad \text{by parallel surfaces} \end{aligned}$$

3.8 Remark

The actual bound here is not very important, and a weakened form of the Signature theorem can be proved with far less care.

The following standard arguement shows that there is a positive integer N say, such that $\beta_2(\tilde{W}_{6n}^{br}) < N$ for all n . By (3.4) there is an exact sequence (coefficients \mathbb{Q})

$$\longrightarrow H_2(\tilde{W}_\infty) \xrightarrow{t_*^{6n-1}} H_2(\tilde{W}_\infty) \xrightarrow{P_*} H_2(\tilde{W}_{6n}) \longrightarrow H_1(\tilde{W}_\infty) \longrightarrow$$

and by (3.3), $H_2(\tilde{W}_\infty)$ and $H_1(\tilde{W}_\infty)$ are finite dimensional, hence

$$\beta_2(\tilde{W}_{6n}^{br}) \leq \beta_2(\tilde{W}_{6n}) \leq \beta_2(\tilde{W}_\infty) + \beta_1(\tilde{W}_\infty).$$

Now $\beta_1(\tilde{M}_{6n}^{br}) \leq \beta_1(\tilde{M}_\infty)$, and so

$$|\tau(\omega, P, \tilde{M}_{6n}^{br})| \leq N \quad \text{for all } \omega, P, n$$

this is the fundamental result used in the proof that certain knots are not ribbon.

Geometry

Generators of $H_2(\tilde{M}_{6n}^{br})$ arise in a particularly nice way. Fig (3.2) shows an immersed ribbon disc with two surgery curves a, b on it. Fig (3.3) shows the boundary of a regular neighbourhood of the ribbon disc, a genus 2 closed surface, which has been cut open along 2 curves parallel to a , and 2 curves parallel to b . The result is 3 surfaces A, B, C . A Seifert surface for 8_{20} is obtained by cutting and cross joining the self intersections in the ribbon disc, resulting in a genus 2 Seifert surface V , (a and b may be isotoped onto V) shown in fig (3.4). Let $X = cl(S^3 - V \times I)$ then fig (3.5) shows the 3 lifts of X to \tilde{M}_3^{br} . A, B, C may be moved slightly in X so that each meets V (along their boundaries only) on the curves a and b . Choosing appropriate lifts of A, B, C to \tilde{M}_3^{br} and identifying along their boundaries, yields a non-orientable closed surface P_3 in \tilde{M}_3^{br} . This is also indicated in fig (3.5), where the numbers adjacent to the boundary components of the chosen lifts of A, B, C indicate the glueing up recipe. The pre-image in \tilde{M}_{6n}^{br} under the covering projection $\tilde{M}_{6n}^{br} \rightarrow \tilde{M}_3^{br}$ is an orientable surface P_{6n} of genus $2n+1$. (There is a 1-cycle in \tilde{M}_{6n}^{br} crossing P_{6n} once, hence $\{P_{6n}\} \neq 0 \in H_2(\tilde{M}_{6n}^{br})$, in fact P_{6n} and $t(P_{6n})$ represent a basis of $H_2(\tilde{M}_{6n}^{br})$, since a 1-cycle can be found intersecting one, but not the other. However we dont need to know any of this) Thus:

$$|\tau(\omega, P_{6n}, \tilde{M}_{6n}^{br})| \leq N \quad \text{for all } \omega, n$$

The process of producing algebraically slice knots from a slice knot described in the introduction is now applied to 8_{20} as shown in Fig (3.6). The band containing the surgery curve b on V is tied into a knot K (with zero twisting) producing a surface V' . This operation clearly preserves the Seifert form, and so the new knot, $k' = \partial V'$, is algebraically slice. We suppose k' to be a ribbon knot, D' a ribbon disc for k' . Then the analysis resulting in the signature bound, depending as it did only on the Λ -module structure of $H_1(\tilde{M}_\infty)$ (which

3.1 The Knot 8_{20}

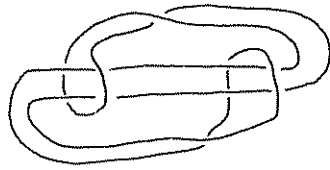

3.2 A ribbon disc

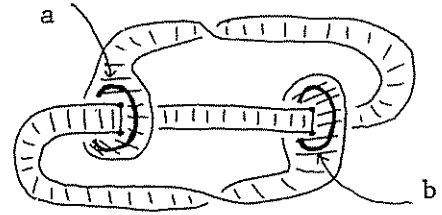

3.3 3 surface pieces

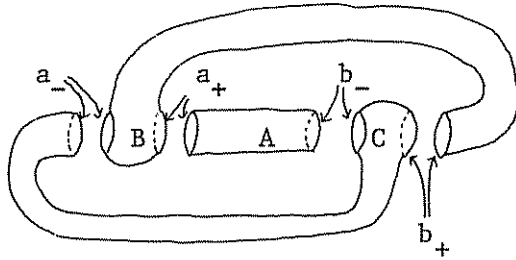

3.4 A Seifert Surface

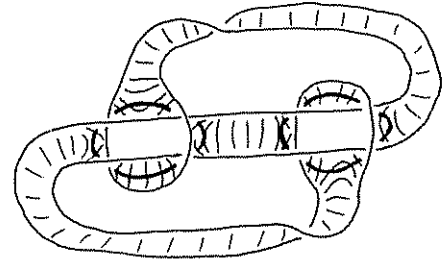

3.5 a non-orientable surface in M_3^{obr}

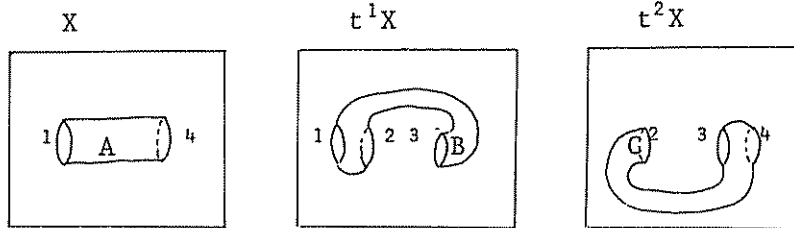

3.6 algebraically slice knot k'

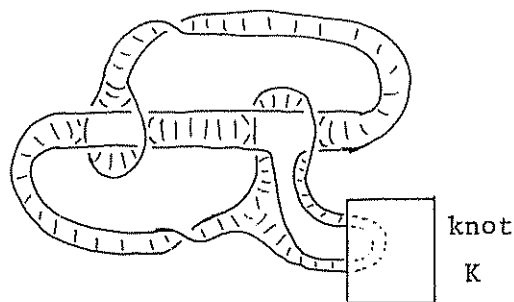

3.7 The arc α

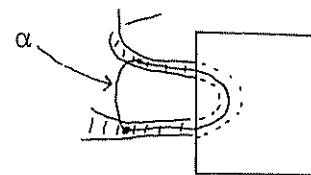

3.8 surface pieces for k'

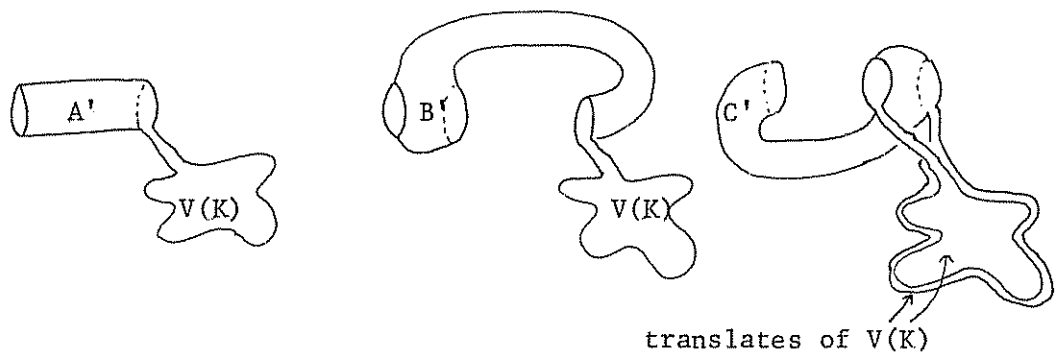

3.9 (i) a knotted hole Y'

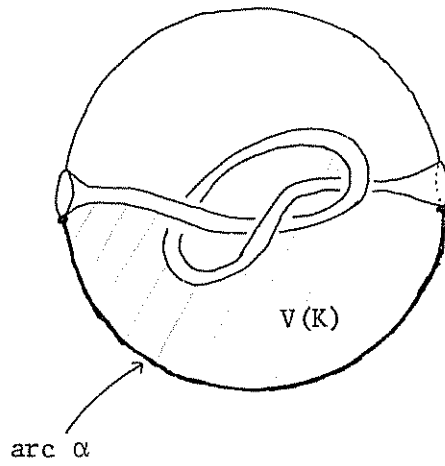

3.9 (ii) the solid torus Y

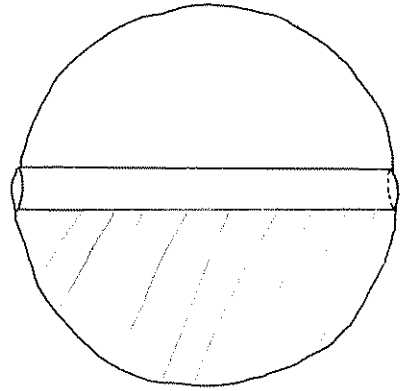

3.10 A slice knot without surgery curves ?

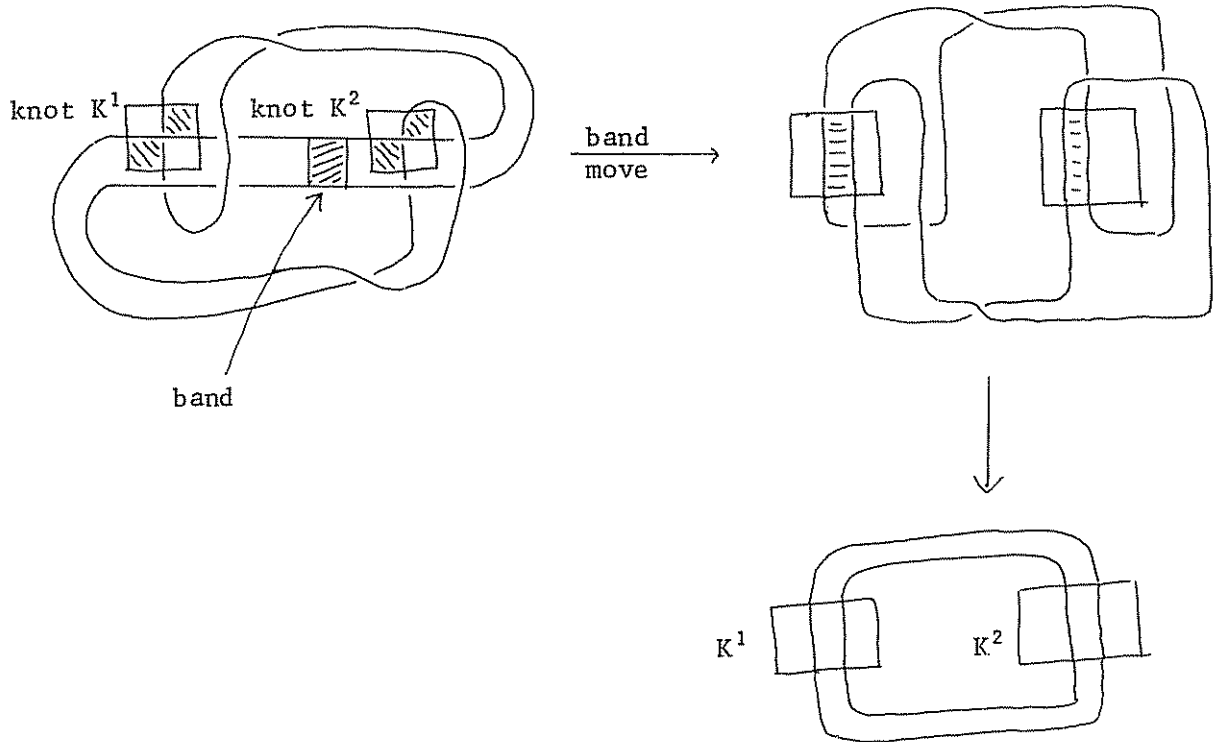

itself is determined by the Seifert form because $H_1(\tilde{M}_\infty)$ is presented by $tA-A'$, A a Seifert matrix for the knot) applies to k' also.

It remains to construct some surfaces in \tilde{M}_{6n}^{br} , Fig (3.7) shows an arc α in S^3-V' which, together with the centre line of the band of V' which was knotted into K , forms a circle embedded in S^3 as the knot K . Let $V(K)$ be a Seifert surface for K , and construct 3 surfaces A', B', C' as shown in Fig (3.8) by attaching copies of $V(K)$ to A, B, C . Then A', B', C' may be used to construct a surface P'_{6n} in \tilde{M}_{6n}^{br} for k' in the same way that A, B, C were used for 8_{20} . It will be shown that :

$$\tau(\omega, P'_{6n}, \tilde{M}'_{6n}{}^{br}) = \tau(\omega, P_{6n}, \tilde{M}_{6n}{}^{br}) + 4n\tau(\omega, K)$$

and the signature bound implies (letting $n \rightarrow \infty$) that:

$$\tau(\omega, K) = 0 \quad \text{for all } \omega, \text{ if } k' \text{ is ribbon.}$$

Fig (3.9 i) shows a 3-ball with a knotted hole Y' , lying in X' (= analog of X for k'). The knot is K , and Y' contains $V(K)$, and is a neighbourhood in X' of the band K lies on. The arc α lies on $\partial Y'$. Y' lifts to $\tilde{M}'_{6n}{}^{br}$ and is joined to $t(Y')$ in $\tilde{M}'_{6n}{}^{br}$ by a disc lying in (a lift of) V' .

Fig (3.9 ii) shows the corresponding construction for 8_{20} , Y is a solid torus. Thus \tilde{M}_{6n}^{br} may be converted into $\tilde{M}'_{6n}{}^{br}$ by replacing the lifts of Y by the lifts of Y' . It should now be clear that :

$$\begin{aligned} & \tau(\omega, P'_{6n}, \tilde{M}'_{6n}{}^{br}) - 2n\{\tau(\omega, A', X') + \tau(\omega, B', X') + \tau(\omega, C', X')\} \\ &= \tau(\omega, P_{6n}, \tilde{M}_{6n}{}^{br}) - 2n\{\tau(\omega, A, X) + \tau(\omega, B, X) + \tau(\omega, C, X)\} \end{aligned}$$

although the Second Additivity theorem may be used to prove this. The only point to watch for is that some orientation change in the cover does not result in everything cancelling out eg.

$$\tau(\omega, \text{lift of } A', \tilde{M}'_{6n}{}^{br}) \neq -\tau(\omega, \text{any other lift of } A', \tilde{M}'_{6n}{}^{br})$$

this cant happen because coverings preserve orientation.

It is clear that:

$$\tau(\omega, A', X') = \tau(\omega, A, X) + \tau(\omega, K)$$

$$\tau(\omega, B', X') = \tau(\omega, B, X) + \tau(\omega, K)$$

and $\tau(\omega, C', X') = \tau(\omega, C, X)$

this last result arises because C' has two parallel copies of $V(K)$ oppositely oriented, so that (eg by parallel surfaces) there is no contribution to τ . This establishes the formula and completes the proof of:

3.9 Theorem

If the knot k' is obtained by tying a knot K in the particular band shown in Fig(3.6) of the Seifert surface for the knot 8_{20} , then if k' is ribbon, then $\tau(\omega, K) = 0$ for all ω .

3.10 Remark

The Casson Gordon method gives this result when $\omega^3 = 1$.

3.11 Remark on Surgery curves

Suppose a knot K^1 is tied in the surgery curve a , and a knot K^2 is tied in the surgery curve b , as shown in Fig(3.10). Then by doing the band move (chap 2,5.7) shown, a link of two components, with linking number zero, is obtained. The two components are parallel (ie each lies inside a tubular neighbourhood of the other) and each is $K^1 + K^2$. If this latter is a slice knot, then two parallel copies of a slice disc for it plus the band, constitute a slice disc for the modified 8_{20} {nb slice can be replaced by ribbon in the foregoing}. Therefore the best non-slice result on the above lines is $\tau(\omega, K^1) + \tau(\omega, K^2) = 0$ for all ω . This is an easy generalisation of our result. If $K^1 =$ (r.h. trefoil), and $K^2 =$ (l.h. trefoil), then $K^1 + K^2$ is slice, but there does not appear to be any pair of surgery curves in this case. (The problem of proving there are not any seems related to the finiteness conjecture). I do not know of another example of this in the literature.

Genus 1 Slice Knots

Let k be a genus 1 slice knot, then it has a Seifert matrix

$$A = \begin{bmatrix} 0 & m+1 \\ m & n \end{bmatrix} \quad m, n \in \mathbb{Z}$$

so the Alexander polynomial, $\Delta(t) = \{(m+1)t - m\}\{mt - (m+1)\}$.

We will assume $m \neq 0$, so $\Delta \neq 1$. Since Δ is not zero for any root of unity, it follows that (eg by Summer's result) $H_1(\tilde{M}_q^{\text{br}}; \mathbb{Q}) = 0$ for all q thus all surfaces in \tilde{M}_q^{br} bound there, so the method used on 8_{20} does not apply. For 8_{20} , the pre-image under the covering $\tilde{M}_\infty \rightarrow \tilde{M}_6$, \tilde{P}_∞ of \tilde{P}_6 is a surface running off to infinity and invariant under translation by t^6 . When the eigenvalues of $A^{-1}A'$ (=roots of $\Delta(t)$) are not roots of unity, such non-trivial surfaces invariant under translation by t^q don't exist. However there are classes

$$\{b\} \in \varprojlim_{X \text{ compact}} H_2(\tilde{M}_\infty, \tilde{M}_\infty - X; \mathbb{Q})$$

which play a similar role. Choose a lift \tilde{V} of V to \tilde{M}_∞ and consider the compact component $X_n \subset \text{cl}\{\tilde{M}_\infty - (t^n V \cup V) \times I\}$. The part of a 2-cycle b , lying in X_n can be multiplied by an integer and then represented by a surface P_n properly embedded in X_n . Now suppose that k is slice, D a slice disc, then $D \cup V \subset W$ bounds a 3-manifold Z properly embedded in W . Let \tilde{Z} be the lift of Z to W with $\tilde{V} \subset \tilde{Z}$ and let Y_n be the compact component of $\text{cl}\{\tilde{W}_\infty - (t^n \tilde{Z} \cup \tilde{Z}) \times I\}$ so $\partial Y_n = X_n \cup t^n \tilde{Z} \cup \tilde{Z}$. If :

$$\{b\} \in \varprojlim_n \{\ker i_* : H_2(\tilde{M}_\infty, \tilde{M}_\infty - X_n) \rightarrow H_2(\tilde{W}_\infty, \tilde{W}_\infty - Y_n)\}$$

then $\{P_n\} = 0 \in H_2(Y_n, t^n \tilde{Z} \cup \tilde{Z}; \mathbb{Q})$ so there is a 3-manifold U , properly embedded in Y_n with

$$\partial Y_n = (\text{multiple of } P_n) + (\text{unknown surfaces in } t^n \tilde{Z} \cup \tilde{Z})$$

these surfaces being joined along their common boundary in $\partial(t^n \tilde{Z} \cup \tilde{Z})$

We will construct suitable P_n and show that $\tau(P_n) \rightarrow \infty$ as $n \rightarrow \infty$ under certain conditions. Because the unknown surfaces lie in \tilde{Z} and $t^n \tilde{Z}$, finiteness and additivity imply their contribution to τ is bounded.

A supply of homology classes to produces P_n from follows from (3.3) if, of course, $H_1(\tilde{M}_\infty) \neq 0$ ie $\Delta(t) \neq 1$. Now for the details, first we collect together some standard bits and pieces.

3.12 Lemma

with Coefficients \mathbb{Q} :

- (1) $2\text{rk}\{i^*: H^1(\tilde{W}_\infty) \longrightarrow H^1(\tilde{X}_n)\} = \beta_1(\tilde{M}_\infty)$
- (2) If P_n is a surface in X_n such that $\{P_n\} \in H_2(X_n, \partial X_n)$ is dual to $i^*\phi$ then $\{P_n\} = 0 \in H_2(Y_n, t^n \tilde{Z} \cup \tilde{Z})$
- (3) If a Seifert matrix for V is non-singular, then

$$\text{incl}_* : H_1(\tilde{V}) \xrightarrow{\cong} H_1(X_n) \xrightarrow{\cong} H_1(\tilde{M}_\infty)$$
- (4) If $j^*: H^1(\tilde{W}_\infty) \longrightarrow H^1(\tilde{V})$ is restriction, and $\alpha \in H_1(V)$ is dual to $j^*\phi$ then $S_V(\alpha, \alpha) = 0$ where S_V is the Seifert pairing on V .
- (5) If α is a surgery curve on V , then $S_V(\alpha, \alpha) = 0$.

Proof: For (3) cf {Mil} by (3.3), $H_1(\tilde{M}_\infty)$ is finite dimensional, so there is a compact subset C containing cycles representing a basis.

Let T_0 be a component of $(\tilde{M}_\infty - \tilde{V} \times I)$, without loss $C \subset T_0$ so

$H_1(\tilde{M}_\infty) \longrightarrow H_1(\tilde{M}_\infty, T_0)$ is zero. By excision $H_1(\tilde{M}_\infty, T_0) \xrightarrow{\cong} H_1(\tilde{M}_\infty - T_0, \tilde{V})$

and so from the exact sequence of the pair $\tilde{M}_\infty - T_0$ and \tilde{V}

$$\rightarrow H_2(\tilde{M}_\infty - T_0, \tilde{V}) \longrightarrow H_1(\tilde{V}) \xrightarrow{\ell} H_1(\tilde{M}_\infty - T_0) \xrightarrow{0} H_1(\tilde{M}_\infty - T_0, \tilde{V}) \rightarrow$$

we see that ℓ is surjective. A Seifert matrix can be interpreted as

the matrix of $i_{-*}: H_1(V) \longrightarrow H_1(S^3 - V)$ using dual bases {(R) p 210}

If i_{-*} is injective, it must be surjective, so $H_2(S^3 - V, i_{-}V) = 0$

thus $H_2(\tilde{M}_\infty - T_0, \tilde{V}) = 0$ ($\tilde{M}_\infty - T_0$ is copies of $S^3 - V$ identified along $i_{-}V$ and $i_{+}V$, a Mayer Vietoris argument now gives the implication)

From the above exact sequence we see that ℓ is injective also, and using

the Mayer Vietoris sequence for $(\tilde{M}_\infty - T_0)$ and T_0 , we see that

$H_1(\tilde{V}) \longrightarrow H_1(\tilde{M}_\infty)$ is an isomorphism, and without the hypothesis on the Seifert matrix it is a surjection. Now $X_n =$ copies of $cl(S^3 - V \times I)$ identified along $V \times 0$, and $V \times 1$, and if i_{-*} is an isomorphism, then the Mayer Vietoris sequence applied to this gives $H_1(\tilde{V}) \longrightarrow H_1(X_n)$ is an isomorphism, proving 3.

Consider the diagram induced by inclusions:

$$\begin{array}{ccc} H^1(\tilde{W}_\infty) & \xrightarrow{i^*} & H^1(X_n) \\ k^* \downarrow & & \downarrow \\ H^1(\tilde{M}_\infty) & \xrightarrow{j^*} & H^1(\tilde{V}) \end{array}$$

by (3.3) and Universal coefficients, $2rk k^* = \beta_1(\tilde{M}_\infty)$, and by the above j^* is always injective, hence $rk i^* = rk k^*$, proving (1).

(2) follows from the commutative diagram below

$$\begin{array}{ccccc} \phi \in & H^1(\tilde{W}_\infty) & & & \\ & \downarrow \text{incl}^* & & & \\ & H^1(Y_n) & \xrightarrow{\text{incl}^*} & H^1(X_n) & \\ \text{duality} \downarrow \cong & & & \cong \downarrow \text{duality} & \\ & H_3(Y_n, \partial Y_n) & & H_2(X_n, \partial X_n) & [P_n] \\ & \partial \downarrow & & \cong \downarrow \text{excision} & \\ & H_2(\partial Y_n) & \xrightarrow{\text{incl}_*} & H_2(\partial Y_n, t^{n\tilde{Z}} \cup \tilde{Z}) & \\ \text{incl}_* \downarrow & & & \text{incl}_* \downarrow & \\ 0 \in H_2(Y_n) & \xrightarrow{\text{incl}_*} & H_2(Y_n, t^{n\tilde{Z}} \cup \tilde{Z}) & 0 & \end{array}$$

For (4) if V is dual to $i^* \phi$, then under the map

$$\partial_0 : H_2(X_n, t^{n\tilde{V}} \cup \tilde{V}) \longrightarrow H_1(t^{n\tilde{V}} \cup \tilde{V}) \xrightarrow{\text{proj}} H_1(\tilde{V})$$

$\alpha = \partial_0 \{V\}$ and $\partial_0 \{V\} = 0 \in H_1(Z)$, so in B^4 there is a 2-chain

$a \in Z_2(Z)$ with $\partial a = \alpha$. Then $S_V(\alpha, \alpha) = Lk_{S^3}(i_{-*} \alpha, \alpha) = i_{-*} a \cdot a$ in B^4 which is seen to be zero because the 2-chains are disjoint, proving (4).

For (5), a surgery curve α on V bounds a smooth disc D in B^4 , and a parallel copy of D in B^4 has boundary a parallel copy of α on V , so $Lk(i_{-*} \alpha, \alpha) = 0$, proving 5.

Let V be a genus one surface for k , $X = \text{cl}(S^3 - V \times I)$, then by duality nullity $i_*: H_1(\partial X; \mathbb{Z}) \longrightarrow H_1(X; \mathbb{Z}) = \beta_1(V)$. We have $\partial X = V_+ \cup (k \times I) \cup V_-$ so $i_{+*} \oplus i_{-*}: H_1(V_+) \oplus H_1(V_-) \xrightarrow{\cong} H_1(\partial X)$. If $\Delta(t) \neq 1$, then A is non-singular, and

$$\ker i_* = \langle \{(m+1)i_{+*} - mi_{-*}\}\alpha, \{mi_{+*} - (m+1)i_{-*}\}\beta \rangle$$

for some $\alpha, \beta \in H_1(V)$. {This is because $t_*: H_1(\tilde{M}_\infty) \longrightarrow H_1(\tilde{M}_\infty)$ has eigen values $(m+1)/m$ and $m/(m+1)$, and $H_1(\tilde{V}) \longrightarrow H_1(\tilde{M}_\infty)$ is an isomorphism by 3.12(3), so $t_*: H_1(\tilde{V}) \longrightarrow H_1(t\tilde{V})$ has the same eigen values} Thus there is a surface P_α properly embedded in X , disjoint from $k \times I \subset \partial X$, with $\partial P_\alpha = \{(m+1)i_{+*} - mi_{-*}\}\alpha$, let P'_α be a parallel surface to P_α then $\text{Lk}(\partial P_\alpha, \partial P'_\alpha) = 0$, therefore $\text{Lk}(\alpha, \text{parallel copy of } \alpha \text{ on } \partial X) = 0$. This means that α is a candidate for a surgery curve on V (by 3.12(5) any surgery curve must satisfy this condition). If α is a slice knot, then k is a slice knot.

Let $t^n \tilde{P}_\alpha$ be the lift of P_α to X_n meeting $t^n \tilde{V}$, and define a surface $P_n(\alpha)$, properly embedded in X_n by:

$$P_n(\alpha) = \sum_{j=1}^n (m+1)^{n-j} m^j t^j(\tilde{P}_\alpha) \quad \text{using parallel copies of the lifts}$$

all the boundary components of $t^j(\tilde{P}_\alpha)$ match up except at ∂X_n . Now $\partial P_n(\alpha) = (m+1)^n \tilde{\alpha} - m^n t^n(\tilde{\alpha})$, and so $\partial P_n(\alpha) \neq 0 \in H_1(X_n)$. Define P_β, \tilde{P}_β similarly and:

$$P_n(\beta) = \sum_{j=1}^n m^{n-j} (m+1)^j t^j(\tilde{P}_\beta)$$

so $\partial P_n(\beta) = m^n \tilde{\beta} - (m+1)^n t^n(\tilde{\beta})$.

By 3.12(3), $H_1(V) \cong H_1(X_n)$, so by duality in X_n $\{P_n(\alpha), P_n(\beta)\}$ represents a basis of $H_2(X_n, \partial X_n)$. If k is a slice knot then by 3.12(1) there is a class $\phi \in H^1(\tilde{W}_\infty)$ with $i^* \phi \neq 0$, and if P_n is dual to ϕ , then P_n bounds in $H_2(Y_n, t^n \tilde{Z} \cup \tilde{Z}; \mathbb{Q})$. By 3.12(4) $S_V(\partial_0 P_n, \partial_0 P_n) = 0$, but ,

α, β is a basis of $H_1(V)$ and $S_V(a\alpha + b\beta, a\alpha + b\beta) = 0$ implies that $a = 0$ or $b = 0$. Therefore $\partial_0 P_n$ is (a multiple of) α or β , so $i_* \phi$ is dual to (a multiple of) $P_n(\alpha)$ or $P_n(\beta)$, furthermore because $\partial_0 P_n$ depends only on ϕ , the use of α or β is independent of n . So we have proved that if k is slice then for $n \geq 1$ either $P_n(\alpha)$ bounds, or for all $n \geq 1$ $P_n(\beta)$ bounds. Thus there is a 3-manifold U_n properly embedded in Y_n with $\partial U_n \cap X_n = rP_n$ for some integer r , and by the Signature theorem $|\tau(\omega, \partial U_n, \partial Y_n)| \leq 2\beta_2(Y_n) + \beta_1(Y_n)$ using second additivity.

$$|\tau(\omega, \partial U_n, \partial Y_n) - \tau(\omega, rP_n, X_n) - \tau(\omega, \partial U_n \cap (t^{n\tilde{Z}} \cup \tilde{Z}), t^{n\tilde{Z}} \cup \tilde{Z})| \leq \beta_1(\partial X_n)$$

Now $\partial Z = \{\text{Seifert surface } V \text{ for } k\} + \{\text{slice disc } D\}$ and V has genus 1 so ∂Z is a torus and the finiteness theorem gives a bound on the signatures of all surfaces properly embedded in $t^{n\tilde{Z}}$ and also in \tilde{Z} . Thus $\tau(\omega, \partial U_n \cap (t^{n\tilde{Z}} \cup \tilde{Z}), t^{n\tilde{Z}} \cup \tilde{Z})$ is bounded. Now $\beta_1(\partial X_n) = 2\beta_1(V)$, and $\beta_r(Y_n)$ is seen to be bounded by applying the Mayer Vietoris sequence to Y_n and $c1(\tilde{W}_\infty - Y_n)$ giving $\beta_r(Y_n) \leq \beta_r(\tilde{W}_\infty) + 2\beta_r(\tilde{Z})$. Thus there is a positive integer N such that

$$|\tau(\omega, rP_n, X_n)| \leq N \quad \text{for all } \omega, n$$

and by using parallel surfaces, r may be taken to be 1.

We proceed to calculate $\tau(\omega, P_n(\alpha), X_n)$ by means of a trick. First suppose that α is a slice knot with slice disc D' , then let $S^3 \times I$ be a collar in B^4 of ∂B^4 , and $V \times I \subset S^3 \times I$ a thickened Seifert surface. Push D' in along the collar and choose $I \times D'$ contained in a product neighbourhood of D' , with $\{I \times D'\} \cap \{V \times I\} = I \times \alpha \times 1 = A$ say, an annulus neighbourhood of α in $V \times 1$. Define $Z = (V \times I) \cup (I \times D')$ joined along A then we have attached a 3-ball to a genus 2 solid handlebody along A producing a solid torus Z . $\partial Z = \{\text{Seifert surface } V\} + \{\text{a slice disc for } k \text{ obtained by surgering } V \text{ along } \alpha\}$ Having done this we find that $\{\alpha\} \in \ker\{i_*: H_1(V) \longrightarrow H_1(Z)\}$, and so in the particular Y_n arising

from this particular choice of Z and D , lemma 3.12(4) implies that $P_n(\beta)$ is bounded, and so $P_n(\alpha)$ must be bounded. In this case there is a bound N_1 , say

$$\text{with } |\tau(\omega, P_n(\alpha), X_n)| \leq N_1 \quad (*)$$

Suppose now that α is not slice, then abstractly the Seifert surface V for k is a disc with 2 bands attached and, because V is a punctured torus, this abstract identification may be made so that α runs once geometrically round one of the bands. If the embedding of V is changed by tying a knot K in this band, and if K is the cobordism inverse of α then the resulting surface V' has boundary a slice knot k' . So (*) is true for $P'_n = P_n(k')$ however using the technique of swapping 3-balls with knotted holes in them used for \mathcal{S}_{20} , we will obtain

$$(1) \quad \tau(\omega, P_n, X_n) = \tau(\omega, P'_n, X'_n) - \sum_{\substack{\text{knotted} \\ \text{balls } B_j}} \tau(\omega, P'_n \cap B_j, B_j)$$

so for k to be slice we must have

$$\left| \sum_{B_j} \tau(\omega, P'_n \cap B_j, B_j) \right| \leq N_1 + N$$

where N is the bound for k , N_1 the bound for k' .

To prove (1) it is necessary to look at P'_n inside a knotted ball. In some $B_j \subset t^j(\tilde{X})$, P'_n is $(m+1)^{n-j} m^j$ parallel copies of a Seifert surface for K . The Second additivity theorem applies, noting that since each component of $P'_n \cap B_j$ has one boundary component only (in ∂B_j) the $\text{rk}(\cdot | \cdot)$ terms are zero, and as for \mathcal{S}_{20} $\text{rk } i_1^* = \text{rk } i_2^* = 1$. Thus the bound in the theorem is 0, proving (1). By the parallel surfaces theorem in B_j

$$\tau(\omega, P'_n \cap B_j, B_j) = \tau(\omega^{(m+1)^{n-j} m^j}, K)$$

which completes the proof of:

3.13 Theorem

If k is a genus one slice knot with non-trivial Alexander polynomial, there is a simple closed curve α on every genus one Seifert surface for k which is non-zero in $H_1(\text{surface})$, and with the properties:

(i) $S_V(\alpha, \alpha) = 0$

(ii) There exists a positive number N such that for all n ,

$$\left| \sum_{j=0}^n \tau(\omega^{(m+1)^{n-j} m^j}, \alpha) \right| < N$$

(iii) The Alexander polynomial of k is $\{(m+1)t - m\}\{mt - (m+1)\}$
 { S_V is the Seifert pairing on V }

3.14 Corollary

The conclusions of the above theorem imply that if p is coprime to m and $m+1$ and G is the subgroup of the units of \mathbb{Z}_p generated by $m/(m+1)$, and if $n \in \mathbb{Z}_p$ and $\omega^p = 1$ then

$$\sum_{r \in nG} \tau(\omega^r, \alpha) = 0$$

Proof: define $x \equiv m/(m+1)$ in \mathbb{Z}_p

$$\text{and } a_j \equiv (m+1)^{n-j} m^j$$

$$\text{then } a_{j+1} \equiv x a_j$$

if $\omega = e^{2\pi i q/p}$ then ω^g for $g \in \mathbb{Z}_p$ is uniquely defined, and if $n \in \mathbb{Z}$

then

$$\sum_{j=0}^{m|G|} \tau(\omega^{n a_j}, \alpha) = m \frac{|G|}{|nG|} \sum_{r \in nG} \tau(\omega^r, \alpha)$$

for m sufficiently large the theorem implies the result.

3.15 Special cases

1) If $p = 2m+1$, $x^2 = 1$ so $G = \{1, x\}$ hence $\tau(1, \alpha) + \tau(\omega, \alpha) = 0$ and since $\tau(1, \text{any knot}) = 0$ we recover the result obtained by Gilmer (Gil) by [his extension of] techniques of Casson and Gordon.

2) If p is coprime to m and $m+1$ then

$$\sum_{r=1}^{p-1} \tau(e^{2\pi i r/p}, \alpha) = 0 \quad \& \quad \int_{\omega \in S^1} \tau(\omega, \alpha) = 0$$

3) if $p = (m+1)^t - m^t$ then $(m/m+1)^t \equiv 1$ in Z_p

and so G has order t . Since p increases rapidly with t , there are a lot of disjoint sets nG , and so many relations between the signatures of α

3.16 Question

does 3.15(2) imply $\tau(\omega, \alpha) = 0$ for all ω ?

§4 Connection with G-signatures

This section gives a relation between $\sigma(\omega, V, M)$ and G signatures of a certain 4-manifold when V and M are closed. This enables an easy proof of the parallel surfaces theorem, and (a version of) the Signature theorem is proved. An account of the use of G signatures as used in knot theory can be found in (G) p 34.

4.1 Definition

Given a closed oriented manifold pair (M^3, V^2) with V not necessarily connected, there is for each integer $n > 0$ an n -fold cover of M determined by V $p: \tilde{M}_n \rightarrow M$. Choose $f: M \rightarrow S^1$ (S^1 oriented) transverse regular at a point x of S^1 with $f^{-1}(x) = V$. The orientations of M and V determine an orientation for the normal bundle of V , f is chosen so that it maps this bundle to that of x 'oriented-bundlewise'. Then \tilde{M}_n is defined by the pull back:

$$\begin{array}{ccc}
 \tilde{M}_n & \xrightarrow{\quad} & S^1 \\
 p \downarrow & & \downarrow \text{n-fold cyclic cover} \\
 M & \xrightarrow{\quad f \quad} & S^1
 \end{array}$$

If the order of $\{V\} \in H_2(M; \mathbb{Z}_n)$ is n then \tilde{M}_n is connected. The group of covering automorphisms of \tilde{M}_n , G , has a canonical generator t , determined by the preferred generator of the S^1 cover specified by the orientation of S^1 .

4.2 Theorem

Suppose W_n is an oriented 4-manifold with $\partial W_n = \tilde{M}_n$ and with G action extending the action on \tilde{M}_n on it's boundary. Suppose also that all components of the fixed point set are surfaces with zero self-intersection. If $\omega^n = 1$, then $\sigma(\omega, V, M)$ is a linear combination of the g-signatures of W_n , $g \in G$.

Proof: {cf (G) p 34, and (V)}

Choose W^4 bounding M such that $0 = i_*: H_2(V) \longrightarrow H_2(W)$ { this can be done by choosing any W with $\partial W = M$, and 'surgering' the components of V , ie if V_1, \dots, V_r are disjoint replace $V_i \times D^2$ by $H_i \times S^1$ in the interior of a collar. $H_i =$ solid handlebody with $\partial H_i = V_i$ }

$p: \tilde{W}_n \longrightarrow W$ is the n -fold cyclic cover of W branched over V pushed into $\text{int}(W)$. \tilde{W}_n can be constructed by taking n copies of W and identifying $V \times [0, 1]$ in the i 'th copy with $V \times [-1, 0]$ in the $(i+1)$ 'th copy, where $V \times [-1, 1]$ is a neighbourhood of V in ∂W . The Mayer Vietoris sequence for \tilde{W}_n gives:

$$\rightarrow H_2(V) \otimes \Lambda \xrightarrow{0} H_2(W) \otimes \Lambda \xrightarrow{i_*} H_2(\tilde{W}_n) \xrightarrow{\Delta} H_1(V) \otimes \Lambda \longrightarrow H_1(W) \otimes \Lambda \rightarrow$$

$\Lambda = \mathbb{C}[Z_n]$. Defining $B' = \text{Im}\{H_2(\partial W) \longrightarrow H_2(W)\}$ we have as usual $H_2(W) = B' \oplus A'$ with $\cdot|A'$ non-singular. Define $B = B' \otimes \Lambda, A = A' \otimes \Lambda$. Then $\text{Im } \Delta = \ker\{j_*: H_1(V) \longrightarrow H_1(W)\} \otimes \Lambda$ and there is a natural isomorphism:

$$\begin{aligned} \ker j_* &\cong \ker\{H_1(V) \longrightarrow H_1(M)\} \oplus \{\text{Im } H_1(V) \longrightarrow H_1(M) \cap \ker H_1(M) \longrightarrow H_1(W)\} \\ &= K_V \oplus C' \quad \text{say} \end{aligned}$$

we will choose $K, C \leq H_2(\tilde{W}_n)$ such that $\Delta: K \xrightarrow{\cong} K_V \otimes \Lambda$
 $\Delta: C \xrightarrow{\cong} C' \otimes \Lambda$

as follows. Given a 1-cycle $\alpha \in Z_1(V)$ with $\{\alpha\} = 0 \in H_1(W)$ choose $a \in C_2(W)$ with $\partial a = \alpha$. Fix a particular copy of W , say W^0 used in the construction of \tilde{W}_n and write a, α for the 'lifts' of these chains to W^0 . Then $\{ta - a\} \in Z_2(\tilde{W}_n)$ where t is the canonical generator of $G \cong Z_n$, so $\{ta\} \in Z_2(tW^0)$. Then $\Delta(ta - a) = \alpha \in Z_1(\tilde{W}_n)$. Because $\cdot|A'$ is non-singular, a may be chosen so that $\{a\} \cdot A' = 0$ (\cdot in W).

Now choose a basis $\alpha_1, \dots, \alpha_r$ of K_V and choose $a_1, \dots, a_r \in C_2(M) \leq C_2(W)$ with $\Delta(ta_i - a_i) = \alpha_i$, this being possible because $K_V = 0 \in H_1(M)$. Define $K = \Lambda$ -module generated by $\{ta_i - a_i\}$ for $1 \leq i \leq r$.

Next choose $\alpha_{r+1}, \dots, \alpha_s$ such that $\{[\alpha_i]\} \quad r < i \leq s$ is a basis of C' , choose a_{r+1}, \dots, a_s with $\Delta(ta_i - a_i) = \alpha_i$ and define $C = \Lambda$ -module generated by $\{ta_i - a_i\} \quad r < i \leq s$.

Observe that $K \cdot i_* (H_2(W) \otimes \Lambda) = 0$ because a class in K can be represented by a cycle in $p^{-1}(M)$, and a class in $i_* (H_2(W) \otimes \Lambda)$ represented by a cycle in $p^{-1}(\text{int } W)$.

Now $H_2(\tilde{W}_n) = A \oplus (B \oplus C \oplus K)$ which decomposes into eigenspaces E^m under the G action corresponding to the eigen values $e^{2\pi im/n} \quad 0 \leq m < n$ of t . A, B, C, K also decompose into A^m, B^m, C^m, K^m and

$$E^m = A^m \oplus (B^m \oplus C^m \oplus K^m)$$

By duality in W there are $b_{r+1}^*, \dots, b_s^* \in B'$ (Kronecker) dual to $[a_{r+1}], \dots, [a_s] \neq 0 \in H_2(W, \partial W)$, it follows that $\text{rk}(\cdot | B^m \oplus C^m) = \dim C^m$ for $0 < m < n$. To see this define for $\omega = e^{2\pi im/n}$

$$a_j^\omega = \sum_{u=0}^{n-1} \omega^{-u} t^u (ta_i - a_i)$$

then $\{a_j^\omega\} \quad 1 \leq j \leq r$ represents a basis of K^m and $\{a_j^\omega\} \quad r < j \leq s$ represents a basis of C^m .

Define

$$b_j^\omega = \sum_{u=0}^{n-1} \omega^{-u} t^u b_j^* \quad r < j \leq s$$

(b_j^* identified with 'lift' to W^0) then $b_j^\omega \in B^m$, and

$$b_j^\omega \cdot a_k^\omega = \sum_{u=0}^{n-1} \omega^{-u} t^u b_j^* \cdot \sum_{v=0}^{n-1} \omega^{-v} t^v (ta_i - a_i)$$

now $t^v a_i \in Z_2(t^v W^0)$ and $t^u b_j^* \in Z_2(t^u \text{int}(W^0))$, therefore if $v \neq u$ then $t^v a_i \cdot t^u b_j^* = 0$, and so (remembering that \cdot is Hermitian)

$$\begin{aligned} b_j^\omega \cdot a_k^\omega &= \sum_{u=0}^{n-1} (\bar{\omega} t^u b_j^* \cdot t^u a_k - t^u b_j^* \cdot t^u a_k) \\ &= \delta_{jk} \sum_{u=0}^{n-1} (\bar{\omega} - 1) \end{aligned}$$

proving the assertion.

Furthermore $B' \cdot B' = 0$ therefore $B^m \cdot B^m = 0$, and so (cf proof of 2.10)

$$\sigma(\cdot | B^m \oplus C^m \oplus K^m) = \sigma(\cdot | K^m) \quad 0 < m < n$$

Now $C^0 = 0$ (it is generated by the cycles $\sum_u t^u (ta_j - a_j) = 0$ for $r < j \leq s$) and so the preceding result holds when $m=0$ also.

$$\text{Claim: (1) } \sigma(\cdot | K^m) = \sigma(\omega, V, M) \quad 0 < m < n$$

$$(2) \quad \sigma(\cdot | A^m) = \sigma(W) \quad 0 \leq m < n$$

to prove these claims, using the basis of K^m chosen above, the intersection pairing on K^m is:

$$a_j^\omega \cdot a_k^\omega = \sum_{u=0}^{n-1} \omega^{-u} t^u (ta_j - a_j) \cdot \sum_{v=0}^{n-1} \omega^{-v} t^v (ta_k - a_k)$$

To compute this, the sections i_+, i_- of the normal bundle of V in M extend to automorphisms of W fixed outside a neighbourhood of V . Define

$a_j^+ = i_+ a_j$, and $a_j^- = i_- a_j$ then $ta_j - a_j$ represents the same class in $H_2(\tilde{W}_n)$ as $ta_j^- - a_j^+$ (again identifying with 'lifts' to W^0). The point

of this is that a_k and a_j^\pm have disjoint boundaries in ∂W , so:

$$(ta_j^- - a_j^+) \cdot t^v a_k = \begin{cases} -a_j^+ \cdot a_k & \text{if } v=0 \\ a_j^- \cdot a_k & \text{if } v=1 \\ 0 & \text{otherwise} \end{cases}$$

now $a_j^- \cdot a_k = S_{V,M}(\partial a_j, \partial a_k)$ {cf definition of $I_{V,M}$ }

and $a_j^+ \cdot a_k = S_{V,M}(\partial a_k, \partial a_j)$ and so

$$\begin{aligned} a_j^\omega \cdot a_k^\omega &= n\{\omega(ta_j - a_j) \cdot t(ta_k - a_k) + (ta_j - a_j) \cdot (ta_k - a_k) + \bar{\omega}(ta_j - a_j) \cdot t^{-1}(ta_k - a_k)\} \\ &= n\{-\omega A_{jk} + A_{jk} + A_{kj} + \bar{\omega} A_{kj}\} \\ &= n\{(1-\omega)A_{jk} + (1-\bar{\omega})A_{kj}\} \end{aligned}$$

{ where $A_{jk} = S_{V,M}(\partial a_j, \partial a_k)$ is a Seifert matrix for the Seifert form on

V } This is the matrix of $S_{\omega, V, M}$ using the basis $\alpha_1, \dots, \alpha_r$ and so (1)

is proved. When $m=0$, $\omega=1$, and the above shows $a_j^\omega \cdot a_k^\omega = 0$, so that in this

case also $\sigma(\cdot | K^0) = \sigma(1, V, M) = 0$.

For (2), let c_1, \dots, c_h be a basis of A' , then

$$c_j^\omega = \sum_{u=0}^{n-1} \omega^{-u} t^u c_j$$

is a basis of A^m and $c_j^\omega \cdot c_k^\omega = n c_j \cdot c_k$ hence $\sigma(\cdot | A^m) = \sigma(\cdot | A) = \sigma(W)$, proving (2). The following is now established:

$$\sigma(\cdot | E^m) = \sigma(\omega^m, V, M) + \sigma(W) \quad 0 \leq m < n \quad \omega = e^{2\pi i/n}$$

g signatures are defined as follows, $H_2(\tilde{W}_n; \mathbb{C})$ decomposes into $H^+ \oplus H^- \oplus H^0$ where the intersection form is +ve definite, -ve definite and zero respectively. For $g \in G$ the g signature is

$$\sigma(g) = \text{trace}(g|H^+) - \text{trace}(g|H^-)$$

By similarly decomposing each eigen space it is seen that

$$\begin{aligned} \sigma(t^r) &= \sum_{m=0}^{n-1} \omega^{rm} \sigma(\cdot | E^m) \quad 0 \leq r < n \quad \omega = e^{2\pi i/n} \\ &= \sum_{m=1}^{n-1} \omega^{rm} \{ \sigma(\cdot | E^m) - \sigma(\cdot | E^0) \} \end{aligned}$$

inverting gives:

$$\sigma(\cdot | E^m) - \sigma(\cdot | E^0) = \frac{1}{n} \sum_{r=1}^{n-1} (\omega^{rm} - 1) \sigma(t^r)$$

now $\sigma(\cdot | E^m) - \sigma(\cdot | E^0) = \sigma(\omega^m, V, M) - \sigma(\omega^0, V, M)$

and $\sigma(1, V, M) = 0$, proving the theorem.

4.3 Remark

In general $\tau(1, V, M) \neq 0$ (Ω in 2.2 example 6) so the identification in terms of G-signatures does not apply to τ .

4.4 Corollary (Parallel Surfaces)

If a surface V is properly embedded in M , and m, n are coprime integers and $\omega^n = 1$, then

$$\sigma(\omega, mV, M) = \sigma(\omega^{|m|}, V, M)$$

Proof: as in (2.26) we may assume $m > 0$. ∂V is a number of disjoint circles in ∂M , attach 2-handles to ∂M as described in (2.18) so that a new surface without boundary is obtained in a new 3-manifold, having the same signatures as the original. Now double this manifold, which again does not change σ . The foregoing construction works for mV , using the same 2-handles, only this time attaching m cores of each handle to the surface mV . Thus if the new surface is V' , and the new manifold M' , we have $\sigma(\omega, V, M) = \sigma(\omega, V', M')$ and $\sigma(\omega, mV, M) = \sigma(\omega, mV', M')$. Therefore it suffices to consider the case of M, V closed.

Since m, n are coprime $\{V\}$ and $m\{V\} \in H_2(M; \mathbb{Z}_n)$ have the same order, and so determine the same n -fold cover $\tilde{M} \rightarrow M$ topologically. However the canonical automorphism t_{mV} for mV is $(t_V)^m$ where t_V is the one for V . Thus the eigen space signatures are related by

$$\sigma_{mV}(\cdot | E^r) = \sigma_V(\cdot | E^{mr})$$

and the result follows by using the connection with $\sigma(\omega, V, M)$ given in the proof of the theorem.

4.5 Remark

The above proof provides an interpretation of the signature of a surface properly embedded in a 3-manifold with boundary, however the method is not very natural. It does not seem that additivity can be proved this way, and in particular any finiteness result.

4.6 Another Signature Theorem

If the compact oriented manifold pair (W^4, U^3) has boundary (M, V) then if p is a prime, $0 < r < p$, and $E_{r/p}$ is the eigen space for eigen value $e^{2\pi ir/p}$ of $H_2(\tilde{W}_p; \mathbb{C})$ then $\dim E_{r/p} \leq \beta_2(W)$ for all except finitely many p . Hence

$$|\tau(\omega, V, M) + \sigma(W)| \leq \beta_2(W) \quad \text{for all } \omega .$$

(\tilde{W}_p is the p -fold cyclic cover of W determined by U)

Proof: Let F be a field, $\Lambda = F[\mathbb{Z}]$, then by (3.4) there is an exact sequence with coefficients F :

$$\rightarrow H_2(\tilde{W}_\infty) \xrightarrow{t-1} H_2(\tilde{W}_\infty) \xrightarrow{P*} H_2(W) \xrightarrow{\partial} H_1(\tilde{W}_\infty) \xrightarrow{t-1} H_1(\tilde{W}_\infty) \rightarrow$$

$$\text{hence} \quad \left. \begin{aligned} \text{coker} \{t-1: H_2(\tilde{W}_\infty) \rightarrow H_2(\tilde{W}_\infty)\} &= nF \\ \text{ker} \{t-1: H_1(\tilde{W}_\infty) \rightarrow H_1(\tilde{W}_\infty)\} &= mF \end{aligned} \right\} \quad (1)$$

where $n + m = \beta_2(W; F)$. Λ is a PID and so

$$H_2(\tilde{W}_\infty) \cong \bigoplus \Lambda / f_i^{n_i} \quad H_1(\tilde{W}_\infty) \cong \bigoplus \Lambda / g_i^{m_i}$$

where $f_i, g_i \in \Lambda$ are irreducible (or zero). By (1), and because ideals are principal, we may sequence f_i and g_i so that

$$\begin{aligned} f_i &= t-1 \text{ or } 0 & \text{for } 1 \leq i \leq n \\ g_i &= t-1 \text{ or } 0 & \text{for } 1 \leq i \leq m \end{aligned}$$

and all the remaining $f_i, g_i \neq t-1$ or 0 .

The exact sequence above may also be applied to the covering

$$\tilde{W}_\infty \rightarrow \tilde{W}_p \text{ resulting in}$$

$$0 \rightarrow \text{coker} \{t^{P-1}: H_2(\tilde{W}_\infty) \rightarrow H_2(\tilde{W}_p)\} \rightarrow H_2(\tilde{W}_p) \rightarrow \text{ker} \{t^{P-1}: H_1(\tilde{W}_\infty) \rightarrow H_1(\tilde{W}_p)\} \rightarrow 0 \quad (2)$$

$$\text{note that} \quad \text{coker } t^{P-1}: \Lambda / f \rightarrow \Lambda / \langle f, t^{P-1} \rangle$$

$$\begin{aligned} \text{ker } t^{P-1}: \Lambda / f \rightarrow \Lambda / \langle f, t^{P-1} \rangle & \cong \Lambda / \langle f, t^{P-1} \rangle & \text{if } f \neq 0 \\ & \cong 0 & \text{if } f = 0 \end{aligned}$$

Now put $F = \mathbb{Z}_p$ in the above, and observe that $t^{P-1} = (t-1)^P$ over \mathbb{Z}_p ,

then (2) becomes:

$$0 \rightarrow \bigoplus_{i=1}^n \Lambda / A_i \rightarrow H_2(\tilde{W}_p; \mathbb{Z}_p) \xrightarrow{h} \bigoplus_{i=1}^m \Lambda / B_i \rightarrow 0 \quad (3)$$

$$\text{where } A_i = \begin{cases} \langle (t-1)^P, (t-1)^{n_i} \rangle & \text{if } f_i \neq 0 \\ \langle (t-1)^P \rangle & \text{if } f_i = 0 \end{cases}$$

$$B_i = \begin{cases} 0 & \text{if } g_i = 0 \\ \langle (t-1)^P, (t-1)^{m_i} \rangle & \text{if } g_i \neq 0 \end{cases}$$

all the other summands are zero.

Thus

$$\beta_2(\tilde{W}_p; \mathbb{Z}_p) = \sum_{i=1}^n \dim_F(\Lambda/A_i) + \sum_{i=1}^m \dim_F(\Lambda/B_i) \leq p\beta_2(W; \mathbb{Z}_p) \quad (4)$$

Now W is compact so $H_x(W; \mathbb{Z})$ is finitely generated, say $= \bigoplus_i \mathbb{Z}/m_i \mathbb{Z}$ for $m_i \in \mathbb{Z}$. Hence for all but finitely many primes p we have :

$$\beta_2(W; \mathbb{Q}) = \beta_2(W; \mathbb{Z}_p)$$

and for such p , (4) implies that :

$$\beta_2(\tilde{W}_p; \mathbb{Q}) \leq p\beta_2(W; \mathbb{Q})$$

(because by Universal Coefficients, $\beta_2(\tilde{W}_p; \mathbb{Q}) \leq \beta_2(\tilde{W}_p; \mathbb{Z}_p)$)

Now use (1) and (2) with coefficients $F = \mathbb{Q}$, in this case $(1 + \dots + t^{p-1})$ is irreducible, hence:

$$\Lambda / \langle f, t^{p-1} \rangle = \Lambda / A$$

where $A = \langle 1 \rangle, \langle t-1 \rangle, \langle 1 + \dots + t^{p-1} \rangle$, or $\langle t^{p-1} \rangle$

so (2) becomes:

$$0 \longrightarrow \bigoplus_{i=1}^n \Lambda/A_i \longrightarrow H_2(\tilde{W}_p; \mathbb{Q}) \longrightarrow \bigoplus_{i=1}^m \Lambda/B_i \longrightarrow 0$$

where A_i, B_i are selected from the last 3 possibilities for A .

A summand $\Lambda / \langle t-1 \rangle$ does not contribute to any eigen space $E_{r/p}$ for $r > 0$ and the other two possible summands each contribute 1 to $\dim_{\mathbb{C}} E_{r/p}$, hence $\dim_{\mathbb{C}} E_{r/p} \leq n + m = \beta_2(W; \mathbb{Q})$, as asserted in the theorem. By (4.1)

$$|\sigma(\omega, V, M) + \sigma(W)| \leq \dim_{\mathbb{C}} E_{r/p}$$

and since this is true for all but finitely many primes p , and all $0 < r < p$, the piecewise constant nature of σ implies that

$$|\tau(\omega, V, M) + \sigma(W)| \leq \beta_2(W; \mathbb{Q}) \quad \text{for all } \omega .$$

The theorem is proved.

4.7 Remark

The intersection pairing vanishes on $\text{Im}\{H_2(\partial \tilde{W}_p) \longrightarrow H_2(\tilde{W}_p)\}$ and so a better estimate for σ may be available by this means. However since $\dim \text{coker}\{H_2(\partial W) \longrightarrow H_2(W)\}$ is not a possible bound, the improvement does not seem obvious.

§5 Further Results & Problems

In this section are collected some questions which are currently unanswered or which space and time prevent a detailed discussion of.

1) Kawauchi has generalised Milnor's duality theorem (Mil) thereby obtaining signatures from elements of $H^1(M; \mathbb{Z})$. For M, V closed the resulting signatures appear to be equivalent to $\sigma(\omega, V, M)$. As noted earlier however, this can't be the case for M having boundary (this failure can in fact be 'explained'). (Kaw2)

2) The finiteness theorem, if generalised (to genus 2 handlebodies) seems to imply that the Seifert surface in Fig (3.10) does not contain any pair of surgery curves. A stronger conjecture than a generalised finiteness theorem is "suppose V_1, V_2 are properly embedded in M , then if $\{V_1\} = \{V_2\} \in H_2(M, \partial M)$, then

$$|\sigma(\omega, V_1, M) - \sigma(\omega, V_2, M)| \leq \frac{1}{2} \beta_1(\partial M) \quad "$$

Evidence for all this is supplied by (2.18), also a band move in ∂M on the components of ∂V does not change σ if one of the components of ∂V involved bounds in ∂M .

3) Does the condition on a genus 1 knot to be slice, given in (3.13) imply $\sigma(\omega, \alpha) = 0$ for all ω ?

4) \mathbb{Z}_p surfaces can be used in place of ordinary surfaces for defining signature for p 'th roots of unity. The surfaces constructed in X_n for genus 1 knots project down to \mathbb{Z}_p surfaces in \tilde{M}_n^{br} , and it seems likely that this is closely related to the Casson-Gordon technique.

5) If $K = 4_1$ in the table of Alexander and Briggs, is used in the construction on 8_{20} (or a genus 1 knot), can the resulting knot be (shown not to be) ribbon?. That 4_1 is not slice is detected by the condition on the polynomial, and not by any signature condition (hard).

6) If genus 2 slice knots are considered, $\Delta(t) = f(t)f(t^{-1})$. Suppose $f(t)$ is quadratic, then if the roots of f are real, surfaces arise as in the genus 1 case. If the roots are complex, then one constructs surfaces in X_n by lifting two different surface pieces and glueing up. This is what happened in 8_{20} (where the surface piece C is equivalent to $A+B$), and the surface in X_n is:

$$P_n = \sum_j (a_j t^j \tilde{A} + b_j t^j \tilde{B})$$

For 8_{20} , because the roots of $f(t)$ are roots of unity, a_j and b_j are periodic in j . In general this does not happen, making the signature behaviour more complex. All this, of course, requires a more comprehensive finiteness result.

§1 Introduction

Given a Seifert surface for a classical knot, there is associated a linking form from which the first homology of the infinite cyclic cover may be obtained. This chapter considers classical links of two components, and shows how to define a pair of linking forms from the analogue of a Seifert surface. From these the first homology of the universal abelian ($\mathbb{Z} \oplus \mathbb{Z}$) cover is obtained, thus giving a practical method of calculating the Alexander polynomial. Also a new signature invariant for links is defined. The method generalises to any number of components, however this is not done here.

Throughout, unless otherwise stated, a link will mean a link of two circles in the 3-sphere. The main results are (2.1) which gives a presentation of the first homology of the cover obtained from the Hurewicz homomorphism of the link complement, and (2.4) which gives a signature invariant obtained from the presentation matrix that vanishes for strongly slice links. This invariant is interpreted in terms of g -signatures in §6. §3 contains a new derivation of the Torres conditions on a link polynomial and §4 shows that these conditions are sufficient for linking number ± 2 when both components are unknotted (this is already known for linking number 0, ± 1). A new proof is given of the result of Kawachi, and independently Nakagawa, on the Alexander polynomial of a slice link.

The material presented here arose out of a study of the method Conway used in (C) to calculate potential functions. A proof of Conway's identities for the Alexander polynomial in one and two variables is given in §7 by manipulating Seifert surfaces, proofs are also given of some of the other results from the same paper.

§2 The Algorithm

In this section a pair of linking forms, generalising the Seifert form, are defined for a link. The matrices of these forms are used to describe the first homology of the universal abelian cover of the link complement.

Let V_x and V_y be compact pl embedded oriented surfaces in S^3 and suppose ∂V_x is disjoint from ∂V_y , and that V_x meets V_y transversely. The components of $V_x \cap V_y$ are of three types called clasp (or C), ribbon (or R) and circle, see Fig (2.1). The 2-complex $S = V_x \cup V_y$ is called a C-complex if all intersections are clasps, an R-complex if all intersections are ribbon, and an RC-complex if ribbon and clasp intersections are present. An orientation for such a 2-complex is an orientation for each of the component surfaces. The boundary of S , ∂S is $(\partial V_x, \partial V_y)$, and the singularity of S , $\epsilon(S) = V_x \cap V_y$.

Given a C-complex, define two bilinear forms

$$\alpha, \beta: H_1(S) \otimes H_1(S) \longrightarrow \mathbb{Z}$$

as follows. A 1-cycle u , is called a loop if whenever an ant walking along u meets $\epsilon(S)$, it does so at an end point of $\epsilon(S)$. Another way of saying this is that a loop behaves 'nicely' on $\epsilon(S)$, by going straight across it (maybe several times) and not going along part of a component of $\epsilon(S)$ then leaving it before the end, see Fig (2.2). Given two elements of $H_1(S; \mathbb{Z})$, represent them by loops u and v say, (this may always be done) and define:

$$\alpha(\{u\}, \{v\}) = \text{Lk}(u^{\bar{-}}, v)$$

$$\beta(\{u\}, \{v\}) = \text{Lk}(u^{-+}, v)$$

where Lk denotes linking number. $u^{\bar{-}}$ is the cycle in S^3 obtained by lifting u off S in the negative normal direction from V_x , and the positive normal direction from V_y . That u is a loop ensures this can be done

continuously along $\varepsilon(S)$, where the only difficulty might arise. u^{-} is obtained by using the negative directions for both V_x and V_y .

Choose a basis $\{\gamma_1, \dots, \gamma_g\}$ of $H_1(V_x)$, and a basis $\{\gamma_{g+1}, \dots, \gamma_{g+h}\}$ of $H_1(V_y)$ and, identifying via inclusion, extend to a basis $\{\gamma_1, \dots, \gamma_{g+h+k}\}$ of $H_1(S)$. Define two integral matrices A, B to be the matrices of the forms α, β using this basis.

Suppose now that L is a link of two components called L_x and L_y pl embedded in S^3 , this is denoted $L = (L_x, L_y)$. A C-complex for L is a connected oriented C-complex S , such that $\partial S = L$. (Lemma (3.2) says that any pair of Seifert surfaces for L may be deformed into a C-complex for L) The Hurewicz homomorphism $\pi_1(S^3-L) \longrightarrow H_1(S^3-L)$ induces a cover \tilde{X} of S^3-L , the universal abelian cover. Define G to be the group of covering automorphisms of \tilde{X} , then $G \cong Z \oplus Z$, and is generated by two translations x and y , obtained by lifting meridians of L_x and L_y . Define $\Lambda = Z[G]$. Then define a $(g+h+k) \times (g+h+k)$ matrix J over

$$\begin{aligned} \text{FOF}(\Lambda) \text{ by } J_{r,s} &= 0 & 1 \leq r \neq s \leq g+h+k \\ &= (y-1)^{-1} & r \leq g \\ &= (x-1)^{-1} & g+1 \leq r \leq g+h \\ &= 1 & g+h+1 \leq r \end{aligned}$$

2.1 Theorem

$H_1(\tilde{X}; Z)$ is presented as a Λ -module by the matrix

$$J(xyA + A' - xB - yB')$$

in particular, this matrix has entries in Λ .

(J.Bailey has obtained a presentation for $H_1(\tilde{X})$ by different means, see (B))

2.2 Corollary

The Alexander polynomial of L is

$$\Delta(x,y) = (y-1)^{-g}(x-1)^{-h} \det(xyA + A' - xB - yB')$$

where $g = 2\text{genus}(V_x)$, $h = 2\text{genus}(V_y)$.

The Alexander polynomial as given in (2.2) may vanish. Following Kawauchi (Kaw), define $\beta(L) = \dim \{H_1(\tilde{X}; \mathbb{Z}) \otimes \mathbb{Q}(\Lambda)\}$ as a $\mathbb{Q}(\Lambda)$ vector space, by (2.1) this is also nullity($xyA + A' - xB - yB'$) as a matrix over the field $\mathbb{Q}(\Lambda)$. When $\beta(L) > 0$, Kawauchi re-defines the Alexander polynomial as the hcf of the $(n-\beta(L))$ -minors of an $n \times n$ presentation matrix for $H_1(\tilde{X}; \mathbb{Z})$ as a Λ -module. We will adopt this definition, except where stated (noteably in §7).

A link is strongly slice if it's components bound disjoint locally flat discs properly embedded in the 4-ball.

2.3 Theorem (Kaw), (N)

If L is strongly slice then $\beta(L) = 1$, and $\Delta(x,y) = F(x,y)F(x^{-1},y^{-1})$ for some $F(x,y) \in \Lambda$, with $F(1,1)=1$.

This generalises the result on the polynomial of a slice knot (G). Let

ω_1, ω_2 be complex numbers of modulus 1, and M the Hermitian matrix

$(1+\bar{\omega}_1\bar{\omega}_2)(\omega_1\omega_2A + A' - \omega_1B - \omega_2B')$, and define:

$$\sigma(\omega_1, \omega_2, L) = \text{signature}(M)$$

$$n(\omega_1, \omega_2, L) = \text{nullity}(M)$$

$$\tau(\omega_1, \omega_2, L) = \lim_{\delta \rightarrow 0^+} \frac{1}{4\delta^2} \int_{\substack{|\theta_1| < \delta \\ |\theta_2| < \delta}} \sigma(\omega_1 e^{i\theta_1}, \omega_2 e^{i\theta_2}, L)$$

σ is called the polychrome signature of L . These definitions are motivated by similar ones for knots (T), (G p 32,37).

2.4 Theorem

- (i) σ and n are invariants of L provided $(1 + \bar{\omega}_1 \bar{\omega}_2) \neq 0$, $\omega_1, \omega_2 \neq 1$
- (ii) If L is strongly slice then $\tau(\omega_1, \omega_2, L) = 0$ for all ω_1, ω_2 .

Conway has suggested that it is more natural to consider:

$$\text{signature}(\omega_1 \omega_2 A + \bar{\omega}_1 \bar{\omega}_2 A' - \omega_1 \bar{\omega}_2 B - \bar{\omega}_1 \omega_2 B')$$

in place of the above. This has the advantage of removing the jump in σ at $1 + \bar{\omega}_1 \bar{\omega}_2 = 0$, at the 'expense' of replacing the connection with the Alexander polynomial by his potential function.

In §6 it is shown that if $\omega_1^p = 1 = \omega_2^q$ with p and q coprime then $\sigma(\omega_1, \omega_2, L)$ may be interpreted in terms of the g -signatures of a certain branched cover of B^4 .

Fig (2.1)

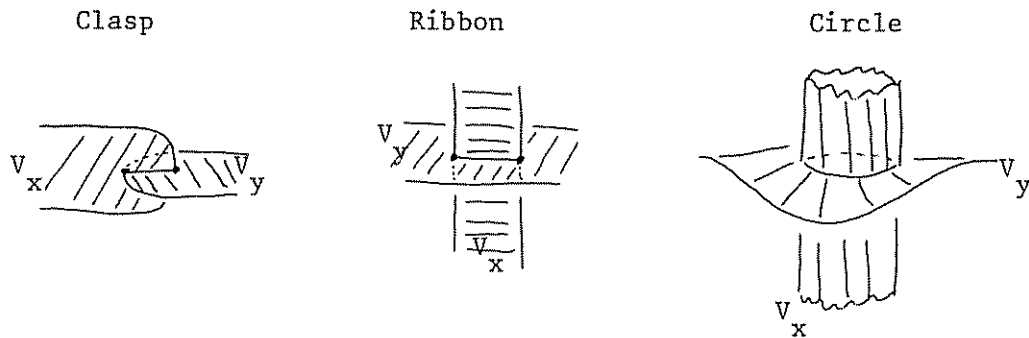
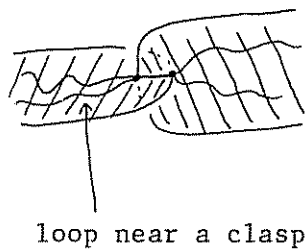

Fig (2.2)



§3 Homology of the cover

In this section we establish the presentation for $H_1(\tilde{X})$ given in (2.1) and then deduce the Torres conditions on a link polynomial. The section ends with some examples. First however we need a supply of C -complexes.

3.1 Definition

Given a surface V with boundary, and an arc $\alpha: [0, 1] \rightarrow V$ with $\alpha(0)$ the only point on ∂V , a push along α is an embedding $p_\alpha: V \rightarrow V$ defined by choosing two regular neighbourhoods of α , N_1 and N_2 , meeting ∂V regularly, with $N_1 \subset N_2$. Then $p_\alpha|_{(V - \text{Int } N_2)} = \text{identity}$, and p_α maps N_2 homeomorphically onto $N_2 - \text{Int } N_1$. See Fig (3.1). Given a pair of Seifert surfaces for a link, a push along an arc α in V_x is allowed only if $N_2 \cap \partial V_y = \emptyset$. That is to say you are not allowed to push one boundary component through the other. A push in V_y is similarly defined.

Fig 3.1

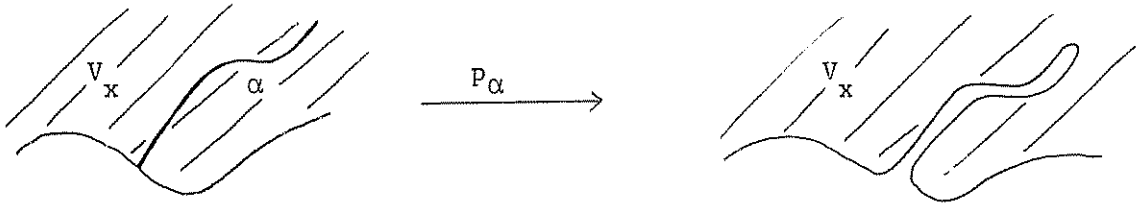

3.2 Lemma

Any pair of Seifert surfaces for a link may be isotoped keeping their boundaries fixed to give a C -complex.

Proof: First make the surfaces transverse, and then remove an outermost on V_x circle component of $V_x \cap V_y$ by pushing in along an arc from V_x to that circle. This transforms the circle into a ribbon intersection. Continue in this way until all circles have been removed, note that this process does not introduce new circles. Next remove the ribbon intersections, in any order, by pushing along an arc from the boundary of one of the surfaces to the ribbon intersection replacing it by two clasps. The

resulting isotopy has moved the link, but only by an ambient isotopy, completing the proof.

3.3 Definition

Let S be an oriented C -complex, then there is a natural splitting

$$0 \longrightarrow H_1(V_x) \oplus H_1(V_y) \longrightarrow H_1(S) \xrightarrow{\hat{\phi}} H_0(\epsilon S) \longrightarrow 0$$

$\nwarrow \hat{\phi}$
 ϕ

given by specifying $\phi(\alpha) \cdot [H_1(V_x) \oplus H_1(V_y)] = 0$ where \cdot is the intersection pairing (which is well defined between the cycles specified)

The basis $\{\gamma_i\}$ of $H_1(S)$ given in §2 is called a preferred basis if

$\{\gamma_{g+h+1}, \dots, \gamma_{g+h+k}\}$ is a basis of $\text{Im } \phi$.

Proof of (2.1)

Define T_x and T_y to be solid torus neighbourhoods of L_x and L_y respectively, and let N be a regular neighbourhood in $S^3 - (T_x \cup T_y)$ of $S \cap \{S^3 - (T_x \cup T_y)\}$. Define $R = \partial N - \partial(T_x \cup T_y)$ and $X = \text{cl}(S^3 - N)$. R may be constructed as follows, let $V'_x = \text{cl}(V_x - (V_x \cap V_y) \times I)$ and $V'_y = \text{cl}(V_y - (V_x \cap V_y) \times I)$. Take 2 parallel copies of V'_x and 2 parallel copies of V'_y and glue up round the clasps $(= (V_x \cap V_y) \times \partial I)$ to form R . The 2 parallel copies of V'_x can be labelled $+, -$ as determined by orientations, similarly for V'_y . Define V_{-+} to be the subset of R $V'_{x-} \cup V'_{y+}$ (see Fig (3.4 ii)) and let i_{-+} be defined by the following commutative diagram:

Fig. (3.2)

$$\begin{array}{ccc}
 H_1(S) & \xrightarrow{i_{-+}} & H_1(X) \\
 \uparrow \cong & & \uparrow \text{incl}_* \\
 H_1(V_{-+}) & \xrightarrow{\text{incl}_*} & H_1(R)
 \end{array}$$

Similarly define i_{--}, i_{+-} and i_{++} (see Figs (3.4) i, iii, iv)

Fig (3.3)

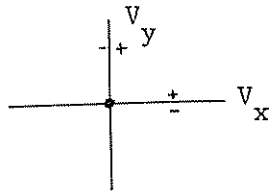

Cross section of a clasp

Fig (3.4) i

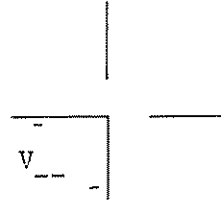

Fig (3.4) ii

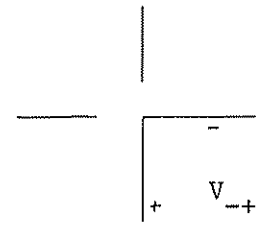

Fig (3.4) iii



Fig (3.4) iv

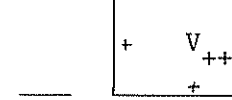
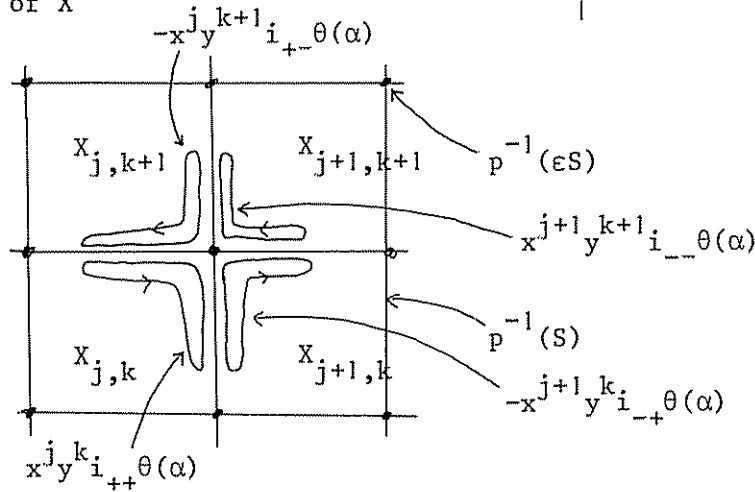

Fig (3.5)

part of \tilde{X}



$$X_{*,*} \cong S^3 - S$$

Write $p: \tilde{X} \rightarrow S^3 - L$ for the universal abelian cover; because S is connected $p^{-1}(S)$ separates \tilde{X} into components which are lifts of X , and so $H_1(\tilde{X}; \mathbb{Z})$ is generated as a Λ -module by (lifts of) $H_1(X; \mathbb{Z})$. By inspection one sees that the following relations hold between these generators:

$$\begin{aligned} \alpha \in H_1(V_x) & \quad i_{++} \theta(\alpha) = xi_{--} \theta(\alpha) \\ \alpha \in H_1(V_y) & \quad i_{++} \theta(\alpha) = yi_{--} \theta(\alpha) \\ \alpha \in \hat{H}_0(\epsilon S) & \quad i_{++} \theta(\alpha) = xi_{+-} \theta(\alpha) + yi_{+-} \theta(\alpha) - xyi_{--} \theta(\alpha) \end{aligned}$$

$\{\theta$ is the natural isomorphism $H_1(S) \cong H_1(V_x) \oplus H_1(V_y) \oplus \hat{H}_0(\epsilon S)\}$. The third set of relations are suggested by Fig(3.5), the proof that this is indeed a presentation of $H_1(\tilde{X}; \mathbb{Z})$ is deferred.

It is clear that:

$$\alpha \in H_1(V_x) \quad i_{--}\theta(\alpha) = i_{-+}\theta(\alpha) \quad \text{and} \quad i_{+-}\theta(\alpha) = i_{++}\theta(\alpha)$$

$$\alpha \in H_1(V_y) \quad i_{--}\theta(\alpha) = i_{+-}\theta(\alpha) \quad \text{and} \quad i_{++}\theta(\alpha) = i_{-+}\theta(\alpha)$$

Therefore the relations may be re-written:

$$\alpha \in H_1(V_x) \quad (y-1)^{-1} \{xyi_{--} + i_{++} - xi_{-+} - yi_{+-}\}\theta(\alpha) = 0$$

$$\alpha \in H_1(V_y) \quad (x-1)^{-1} \{xyi_{--} + i_{++} - xi_{-+} - yi_{+-}\}\theta(\alpha) = 0$$

$$\alpha \in \hat{H}_0(\mathcal{E}S) \quad \{xyi_{--} + i_{++} - xi_{-+} - yi_{+-}\}\theta(\alpha) = 0$$

The linking forms $\alpha, \beta: H_1(S) \oplus H_1(S) \rightarrow \mathbb{Z}$ are given by:

$$\alpha(\{u\}, \{v\}) = \text{Lk}(i_{--}u, v)$$

$$\beta(\{u\}, \{v\}) = \text{Lk}(i_{-+}u, v)$$

and the matrices A, B of α, β with respect to a basis are also the matrices of i_{--} and i_{-+} with respect to a dual basis of $H_1(X)$. Observing that $\text{Lk}(i_{--}u, v) = \text{Lk}(u, i_{++}v)$ it follows that the matrix of i_{++} is A' and in a similar fashion, the matrix of i_{+-} is B'. This transforms the presentation above for $H_1(\tilde{X})$ into the form given in (2.1).

Derivation of relations

A presentation for $H_1(\tilde{X}; \mathbb{Z})$ is given by:

$$H_1(p^{-1}(R)) \xrightarrow{j \oplus k} H_1(p^{-1}(X)) \oplus H_1(p^{-1}(N)) \longrightarrow H_1(\tilde{X}) \longrightarrow 0$$

(this is from the Mayer Vietoris sequence for $p^{-1}(X), p^{-1}(N)$) We will show that k is surjective so that $H_1(\tilde{X}) \cong H_1(p^{-1}(X))/j \ker k$. In order to compute $H_1(p^{-1}(N))$, retract N down onto a 1-dimensional spine formed by the spines P_x of $V_x - T_y$ and P_y of $V_y - T_x$. Initially suppose that V_x and V_y are discs, then P_x is a wedge of circles, one for each clasp. Cut open these circles in P_x to create a tree P'_x (see Fig 3.6), and similarly create P'_y . Label the clasps of S 1 to $(n+1)$, and label the terminal vertices of P'_x $1^+, 1^-, 2^+, 2^-, \dots, (n+1)^+, (n+1)^-$, where the \pm sign is determined by the direction L_y pierces V_x at the clasp. The vertices of P'_y are similarly labelled.

$$\tilde{P} = \text{spine } p^{-1}(N) \doteq \{(P'_x \cup P'_y) \times (\mathbb{Z} \oplus \mathbb{Z})\} / \sim$$

where \sim identifies vertices labelled $-$ in $P'_x(i+1, j)$ with their counterparts labelled $+$ in $P'_x(i, j)$; $-$ vertices in $P'_y(i, j+1)$ with $+$ vertices in $P'_y(i, j)$; and $-$ vertices in $P'_x(i, j)$ with the corresponding $-$ vertices in $P'_y(i, j)$.

Fig (3.6)

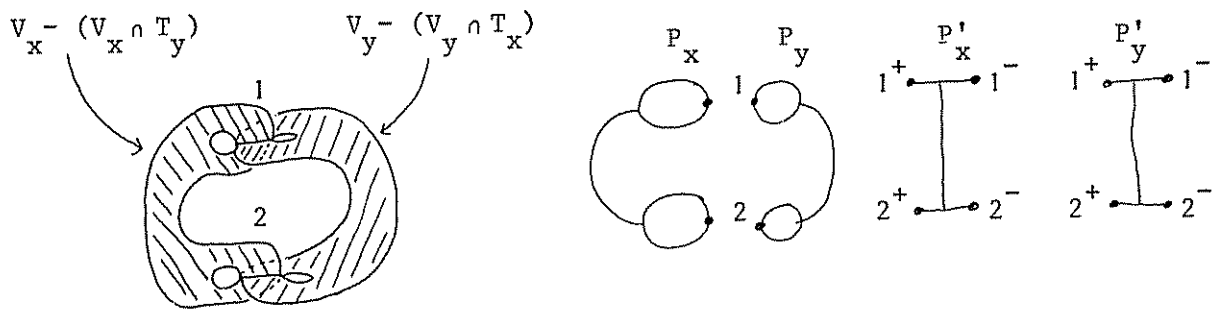

Choose $2n$ 1-chains $\alpha_\ell^\pm \in C_1(P'_y)$ with $\partial \alpha_\ell^\pm = (\ell+1)^\pm - \ell^\pm \quad 1 \leq \ell \leq n$
 and $2n$ 1-chains $\beta_\ell^\pm \in C_1(P'_x)$ with $\partial \beta_\ell^\pm = (\ell+1)^\pm - \ell^\pm \quad 1 \leq \ell \leq n$

then $3n+1$ 1-cycles in $Z_1(\tilde{P}) \otimes \Lambda$ are defined as follows:

$$\begin{aligned} \kappa_\ell &= \alpha_\ell^- - \beta_\ell^- & 1 \leq \ell \leq n \\ \lambda_\ell &= \alpha_\ell^- - y^{-1} \alpha_\ell^+ & 1 \leq \ell \leq n \\ \mu_\ell &= \alpha_\ell^- - x^{-1} \beta_\ell^+ & 1 \leq \ell \leq n \end{aligned}$$

ν = cycle running round 4 lifts of one vertex

$$(p \rightarrow xp \rightarrow xyp \rightarrow yxyp \rightarrow p)$$

then it is clear that these cycles freely generate $H_1(\tilde{P}) \cong H_1(p^{-1}(N))$ as a Λ -module.

Fig (3.7) Part of \tilde{P}

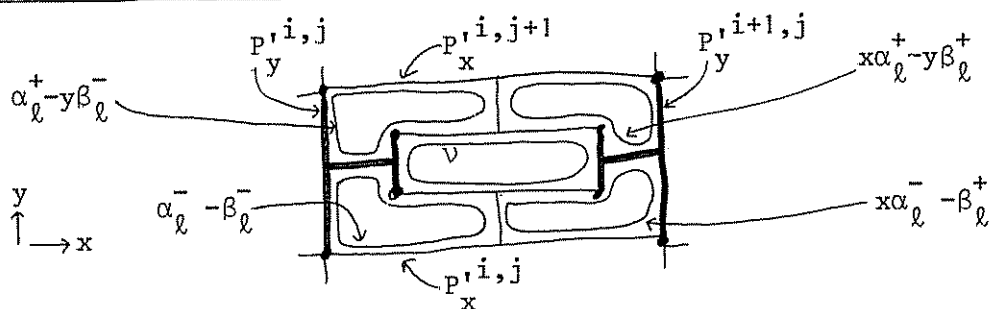

Next we calculate $H_1(p^{-1}(R))$, R lifts to \tilde{X} so $H_1(p^{-1}(R)) \cong H_1(R) \otimes \Lambda$ and $H_1(R) \cong 4\hat{H}_0(\epsilon S) \oplus \langle \bar{v} \rangle$, where \bar{v} is represented by a cycle running round the four glued up segments round some chosen clasp ($\bar{v} = p(v)$) .
 The labelling of the clasps determines a labelled basis of $\hat{H}_0(\epsilon S)$ namely $\{[\text{vertex}(\ell+1)] - [\text{vertex}(\ell)]\}$ $1 \leq \ell \leq n$, and via $\phi: \hat{H}_0(\epsilon S) \longrightarrow H_1(S)$ a basis $\{\gamma_i\}$ of $H_1(S)$. Then a basis of $H_1(R)$ as a \mathbb{Z} -module (and $H_1(p^{-1}(R))$ as a Λ -module) is $\{\bar{v}, i_{--}\gamma_\ell, i_{-+}\gamma_\ell, i_{++}\gamma_\ell, i_{+-}\gamma_\ell\}$ (abuse of i_{--} and the other maps comes from factoring through $H_1(R)$ as shown in Fig (3.2))

We can now describe the map $k: H_1(p^{-1}(R)) \longrightarrow H_1(p^{-1}(N))$ using these bases (refer to Fig (3.7))

$$k(\bar{v}) = v$$

$$k(i_{--}\gamma_\ell) = \alpha_\ell^- - \beta_\ell^- = \kappa_\ell$$

$$k(i_{+-}\gamma_\ell) = x\alpha_\ell^- - \beta_\ell^+ = x\mu_\ell$$

$$k(i_{-+}\gamma_\ell) = \alpha_\ell^+ - y\beta_\ell^- = y(\kappa_\ell - \lambda_\ell)$$

$$k(i_{++}\gamma_\ell) = x\alpha_\ell^+ - y\beta_\ell^+ = xy(\mu_\ell - \lambda_\ell)$$

from which it follows that k is surjective and $\ker\{k\}$ is generated by:

$$(xyi_{--} + i_{++} - xi_{-+} - yi_{+-})\gamma_\ell$$

This completes the derivation of the relations in the case that V_x and V_y are discs. In the general case when V_x and V_y have non-zero genus, $H_1(R)$ is enlarged by $2H_1(V_x) \oplus 2H_1(V_y)$. The construction of \tilde{P} proceeds much as before, except that P'_x is not a tree any longer, having a wedge of circles arising from $\text{spine}(V_x)$, similarly P'_y . This means that extra elements are added to the basis of $H_1(\tilde{P})$ and $H_1(p^{-1}(R))$, and $\ker\{k\}$ is enlarged by $(xi_{--} - i_{++})H_1(V_x)$ and $(yi_{--} - i_{++})H_1(V_y)$ as required, completing the proof of (2.1).

3.4 Definition

A tangle is a proper embedding of two oriented arcs, and any number of oriented circles in a 3-ball.

3.5 Lemma

Suppose a knot, or link, L is separated by a 2-sphere S into two tangles in S^3 . Then a Seifert surface may be chosen for each component of L such that the totality of these surfaces meet S transversely in two arcs.

This will be used to prove various identities between invariants of related links in §7.

Proof: Number the points of intersection of L with S 1 to 4, and choose a component B of $\overline{S^3 - S}$. We suppose the numbering is done so that there is an arc in B whose endpoints are 1 and 2, and another arc in B whose endpoints are 3 and 4. Choose two disjoint arcs on S , α with endpoints 1 and 2, and β with endpoints 3 and 4. The components of the link in B formed by α, β and $L \cap B$ bound surfaces in B which meet S in α and β (eg Seifert's algorithm for tracing out Seifert circuits applied to each component in turn will produce such surfaces). Similarly there is a surface in $\text{cl}(S^3 - B)$ also meeting S in α and β only. These two sets of surfaces joined along α and β are the required surfaces.

3.6 Theorem (Torres)

The Alexander polynomial of a link L of two components satisfies:

$$(i) \quad \Delta(x, y) \doteq \Delta(x^{-1}, y^{-1})$$

$$(ii) \quad \text{If } \beta(L) = 0 \text{ then } \Delta(x, 1) \doteq \Delta(x) \cdot (1-x^{\ell}) / (1-x)$$

where \doteq denotes equality up to multiplication by a unit of Λ ie $\pm x^r y^s$.

ℓ is the linking number of the two components. $\Delta(x)$ is the Alexander polynomial of the x -component.

Proof: (i) is immediate from (2.1). For (ii), using a preferred basis of $H_1(S)$ the linking matrices A,B have the shape:

$$A = \begin{matrix} & H_1(V_x) & H_1(V_y) & \hat{H}_0(\epsilon S) \\ \begin{matrix} H_1(V_x) \\ H_1(V_y) \\ \hat{H}_0(\epsilon S) \end{matrix} & \begin{bmatrix} C & D & E \\ D' & F & G \\ E' & G' & K \end{bmatrix} & & \end{matrix} \quad B = \begin{bmatrix} C & D & E \\ D' & F' & G \\ E' & G' & L \end{bmatrix}$$

If $\beta(L) = 0$ then

$$\Delta(x,1) = \det \begin{bmatrix} xC-C' & (x-1)D & (x-1)E \\ 0 & F-F' & 0 \\ 0 & 0 & x(K-L)+(K-L)' \end{bmatrix} \\ = \det(xC-C') \det(F-F') \det(xM+M') \quad ; M = K - L$$

Now C is a Seifert matrix for the x-component, so $\det(xC-C')=\Delta(x)$. F is a Seifert matrix for the y-component so $\det(F-F') = 1$. Finally we show below that $\det(xM+M')$ depends only on the linking number of the two components, and evaluating for a simple link gives $(1-x^l)/(1-x)$, see (4.7).

It is well known that any knot can be changed into the unknot by changing crossovers, this is easily extended to: any link may be changed into any other link of the same linking number by changing crossovers at which both strings belong to the same component. Let L' be the link L with a single such crossover changed. Using (3.5) choose a C-complex S for L such that a C-complex S' for L' is obtained by adding a full twist to one of the component surfaces of S next to the changed crossover,

Fig (3.8)

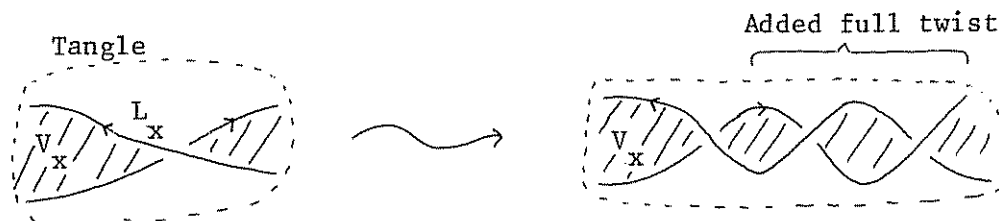

The matrix M is the matrix of $(\alpha-\beta) \hat{H}_0(\epsilon S)$, and adding a twist to S changes α and β by adding to each a symmetric form γ . Thus $\alpha-\beta$ is unchanged, completing the proof.

3.7 Lemma (Kaw corol 2.3)

Let $L = (L_x, L_y)$ be a link of two components, then $\beta(L) = 0$ or 1 .

Proof: If $\Delta_L(x, y) \neq 0$ then M is a torsion module, so $\beta(L) = 0$. Otherwise $\Delta_L(1, 1) = \text{Lk}(L_x, L_y) = 0$, choose a C -complex S for L and let S_1 be obtained from S by removing one clasp, so that S_1 is a C -complex for a link L_1 with linking number $= \Delta_{L_1}(1, 1) = \pm 1$. Thus the module M_1 for L_1 is a torsion module. Putting back the clasp adds a single row and column to a presentation matrix for M_1 giving a presentation matrix for M . This latter has nullity (equal to $\beta(L)$) at most 1, completing the proof.

3.8 Proposition

If L is a link of two components with $\beta(L) = 1$ then $\Delta(x, 1) \mid \Delta_{L_x}$ and in particular $\Delta(1, 1) = \pm 1$.

Proof: In the proof of (3.6), if $\beta(L) = 1$, $xM + M'$ must be singular and, as in the proof of (3.7), we may assume that removing the last row and column gives a non-singular matrix, with determinant $\Delta(x)$. Hence a generator of the (principle) ideal generated by the $(n-1)$ minors divides $\Delta(x)$, completing the proof.

3.9 Definitions

A boundary link is a link whose components bound disjoint Seifert surfaces. A split link is a link in which the components can be separated by 2-spheres. A pure link is a link all of whose components are unknotted.

Remark: for a boundary link it is clear that $\Delta(x, 1) = \Delta_{L_x}$.

3.10 Corollary

If V_x and V_y form a C -complex for L , and k is the number of clasps then

$$k \geq 1 + \beta(L) + \text{degree}_x \Delta(x, y) - 2\text{genus}(V_x)$$

unless $\beta(L) = 1$ and $\text{degree}_x \Delta(x, y) = 2\text{genus}(V_x)$ □

3.11 Examples

1) The method of using C-complexes makes it easy to construct links with a specified $H_1(\tilde{X})$. To illustrate this, we produce a link having the same $H_1(\tilde{X})$ as the unlink, by starting with a C-complex for the unlink and then knotting or geometrically linking the isthmuses used for the clasps

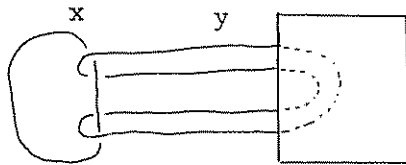

Tie into a knot k
without twisting.

The 2-fold cover of S^3 branched over the (unknotted) x -component contains two lifts of the y -component each of which is $k\#k$, hence the link is non-trivial.

2) Below is a strongly slice link with $\Delta(x,y) = 1$ and $\Delta_{L_x} = (x^2-x+1)^2$ so the link cannot be a boundary link.

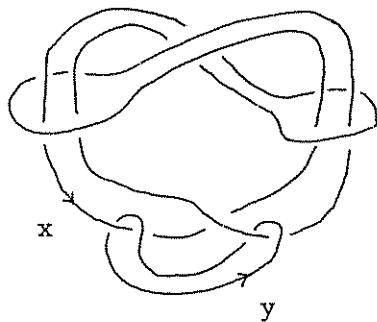

link

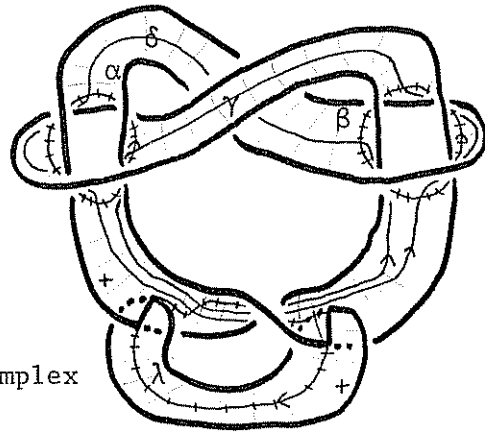

C-complex

$$A = B =$$

λ	α	β	γ	δ
0	0	0	0	0
0	0	0	0	-1
0	0	0	1	1
1	-1	1	2	1
1	-1	0	1	-1

$$J(xyA + A' - xB - yB') =$$

0	0	0	1-y	1-y
0	0	0	1	1-x
0	0	0	x-1	x
x	-x	x-1	2x-2	x-1
x	1-x	-1	x-1	1-x

$$\Delta = \text{hcf}\{x^2-x+1, (1-y)(1-2x), (1-y)(-x)\}. \text{hcf}\{x^2-x+1, x, x(2-x)\} = 1$$

3) This is an example of a pure split link, two different C-complexes are used for giving a presentation of $H_1(\tilde{X})$, one using disjoint Seifert surfaces, the other using a C-complex formed from two discs. Fortunately both give the same module!

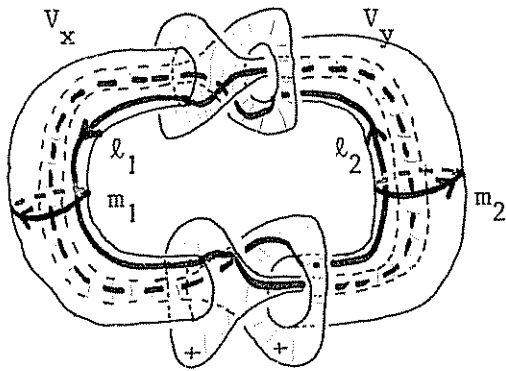
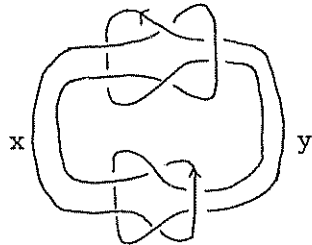

$$A/B = \begin{bmatrix} m_1 & m_2 & l_1 & l_2 \\ 0 & 0 & 0 & 1 \\ 0 & 0 & 1 & 1/0 \\ 1 & 1 & 0 & 0 \\ 1 & 0/1 & 0 & 0 \end{bmatrix}$$

entries of A and B coincide except where shown.

This C-complex is not connected, this can be achieved by adding a trivial pair of clasps which enlarges both A and B by a row & column of zeroes.

The resulting presentation of $H_1(\tilde{X})$ is:

$$\begin{bmatrix} 0 & 0 & 0 & 0 & 0 \\ 0 & 0 & 0 & -1 & x-1 \\ 0 & 0 & 0 & y-1 & y \\ 0 & x & x-1 & 0 & 0 \\ 0 & y-1 & -1 & 0 & 0 \end{bmatrix}$$

which gives the module $\Lambda \oplus \Lambda/(xy-x+1) \oplus \Lambda/(xy-y+1)$

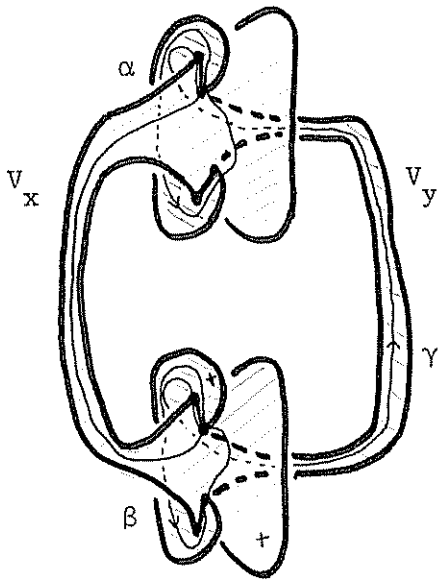

$$A/B = \begin{array}{c} \alpha \quad \beta \quad \gamma \\ \left[\begin{array}{ccc} 0 & 0 & 1/0 \\ 0 & 0 & -1/0 \\ 1 & -1 & 0 \end{array} \right] \end{array}$$

This gives the presentation:

$$\left[\begin{array}{ccc} 0 & 0 & xy+1-y \\ 0 & 0 & -(xy+1-y) \\ xy+1-x & -(xy+1-x) & 0 \end{array} \right]$$

which again gives the module $\Lambda \oplus \Lambda/(xy-x+1) \oplus \Lambda/(xy-y+1)$

Incidentally, this link is also strongly slice, and the module structure is as predicted by (3.3).

54 Generating Link polynomials

The Torres conditions on a polynomial are known to characterise 2-component link polynomials for linking numbers 0 and ± 1 , see (B),(L). On the other hand Hillman has shown (H) that (for linking number $|\ell| \geq 6$) there is an additional necessary condition when the Alexander polynomial of one of the components has a cyclotomic factor which divides $(x^{|\ell|}-1)$. This suggests looking at links in which both components have trivial Alexander polynomial, and we show that under this extra hypothesis that the Torres conditions also suffice when $|\ell| = 2$. It is also shown that every link polynomial is generated by a link in which each component has a Seifert surface of minimal genus compatible with $\Delta(x,1)$ and $\Delta(1,y)$. In particular for $\ell = 0$, all link polynomials are realised by pure links, and if $\ell \neq 0$, and $\Delta(x,1) = (1-x^{|\ell|})/(1-x)$ and $\Delta(1,y) = (1-y^{|\ell|})/(1-y)$ then Δ is the polynomial of a pure link.

4.1 Definition

Given a C-complex $V_x \cup V_y$ for an oriented link (L_x, L_y) , define an intersection permutation in the permutation group on n elements as follows. On V_x choose a clasp and label it 1, then going round V_x in the direction given by the orientation of L_x , label the remaining clasps $2, \dots, n$. Now do the same on V_y starting from the same clasp 1. There is thus a correspondence $i \rightarrow \sigma(i)$ for $1 \leq i \leq n$ where $\sigma(i)$ is the label given by V_y to the clasp labelled i on V_x . This is defined up to choice of clasp labelled 1, ie up to conjugation of σ by ρ^r , where ρ is the n -cycle $\rho(i) \equiv i+1 \pmod n$.

4.2 Lemma

Every link has a C-complex for which the intersection permutation is the identity.

Proof:

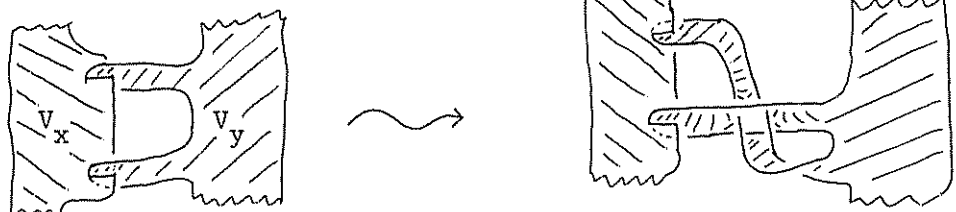

□

4.3 Definition

An equivalence relation on the set of C-complexes for links is defined by requiring:

- (i) All C-complexes for the same link to be equivalent.
- (ii) If two C-complexes for different links have the same linking forms (identified via some homeomorphism of C-complexes) they are equivalent.

this is called S-equivalence . It is clear that S-equivalent C-complexes determine isomorphic homology modules for their respective covering spaces.

4.4 Proposition

Every C-complex is S-equivalent to one in which the Seifert pairings on each individual surface are non-singular.

Proof: Trotter (T1) proves that given a knot k with Seifert surface V and Seifert matrix A (using some basis of $H_1(V)$) there is another knot k' with Seifert surface V' and Seifert matrix A and a second Seifert surface V'' for k' having non-singular Seifert matrix A'' .

Given a link (L_x, L_y) , choose knots L'_x and L'_y as above lying in S^3 and separated from each other by a 2-sphere. Let the surfaces for these knots (having the same Seifert matrices as the given surfaces V_x, V_y for L_x, L_y) be V'_x and V'_y . Regarding V'_x and V'_y as discs with bands attached, link the bands of V'_x with those of V'_y in the same manner as those of V_x and V_y are linked. Next introduce the required number of clasps between V'_x and V'_y ensuring that the intersection permutation is the same as for $V_x \cup V_y$ and link the isthmuses used for the clasps in the same way as those of $V_x \cup V_y$ are linked. The resulting link L' (=boundary of new V'_x, V'_y) has been constructed to have the same linking matrices A, B as the given C-complex for L . However L' possesses another C-complex obtained by deforming minimal Seifert surfaces V''_x, V''_y for L'_x, L'_y which gives the required C-complex, completing the proof.

4.5 Corollary

If a link L has Alexander polynomial Δ with

$$\Delta(x,1) = \Delta(1,x) = (1-x^{|\ell|})/(1-x)$$

then there is a pure link having the same Alexander polynomial as the original.

Proof: If $\ell \neq 0$, the Torres conditions imply that the Alexander polynomial of each component is trivial, and this implies that non-singular Seifert matrices for the components are trivial (ie 0×0) so that the previous result provides a link L' whose components bound discs, as required.

For $\ell = 0$, the result follows from the proof of (4.10) which shows that all such polynomials arise from pure links.

4.6 Definition

Following Conway, we define the potential function of a link to be

$$\nabla(x,y) = \det\{xyA + x^{-1}y^{-1}A' - xy^{-1}B - x^{-1}yB'\} \cdot \det J \cdot \det \bar{J}$$

this is defined up to multiplication by ± 1 (but see §7). Clearly

$$\nabla(x,y) = \pm x^r y^s \Delta(x^2, y^2) \quad , \text{ and the reason for introducing } \nabla \text{ is}$$

to simplify the symmetry property of the Alexander polynomial. The potential function of a knot we will take to be $\nabla(x) = \det\{xA + x^{-1}A'\}$ {Conway has an extra factor of $(x - x^{-1})$ here} .

4.7 The Simple Link

The simple link of linking number ℓ is the $(2, 2\ell)$ torus link, (R) p 53 . Another way of describing this is the boundary of an annulus in S^3 whose core is unknotted with ℓ full twists in, the orientation of components is such that they both represent the same class in $H_1(\text{annulus})$. It will be convenient to have a standard C-complex for the simple link

$\ell \geq 0$ clasps

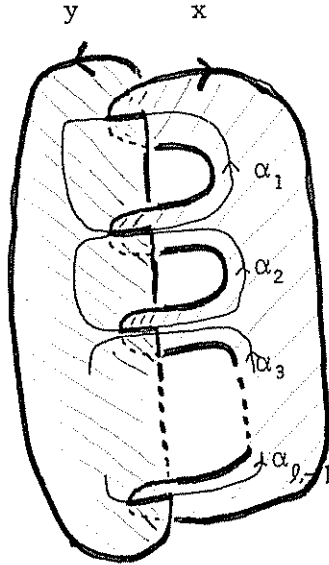

L_ℓ is the matrix

$$xyA+x^{-1}y^{-1}A'-xy^{-1}B-x^{-1}yB'$$

for the simple link using the C-complex and basis shown.

$$L_2 = -(xy + 1/xy)$$

$$L_\ell = \begin{bmatrix} L_{\ell-1} & 0 \\ 0 & xy - xy^{-1}/xy \end{bmatrix}$$

$$\text{define } P_\ell = \det L_\ell = (-1)^{\ell+1} \frac{(xy)^\ell - (xy)^{-\ell}}{xy - (xy)^{-1}} \quad \text{for } \ell \geq 0$$

For $\ell \leq 0$, changing the crossovers in the above diagram gives a C-complex for this case, and it is clear that this multiplies the matrices A,B by -1 . Thus $P_{-\ell} = (-1)^{\ell-1} P_\ell$.

A potential satisfies the Torres conditions if and only if it may be written as:

$$L_\ell \nabla_x \nabla_y + \lambda h(x,y) \quad \text{where } \lambda = (x-1/x)(y-1/y)$$

∇_x, ∇_y are the potentials of the components and :

$$\text{if } \ell \text{ is even then } h \in \Lambda_{\text{sym}}^{\text{even}} \quad \text{if } \ell \text{ is odd then } h \in \Lambda_{\text{sym}}^{\text{odd}} .$$

Λ_{sym} is the subset of Λ of polynomials with $h(x,y) = h(x^{-1}, y^{-1})$

and Λ^{odd} is the subset of Λ in which polynomials only have terms of odd degree in both x and y, Λ^{even} is the subset in which polynomials only have terms with even degree in both x and y. Then

$$\Lambda_{\text{sym}}^{\text{odd}} = \Lambda_{\text{sym}} \cap \Lambda^{\text{odd}} \quad \text{and} \quad \Lambda_{\text{sym}}^{\text{even}} = \Lambda_{\text{sym}} \cap \Lambda^{\text{even}} .$$

define $x^{r_i} y^{s_i} = \prod_{k=1}^{i-1} \alpha_k$ so $x^{-r_i} y^{-s_i} = \prod_{k=1}^{i-1} \beta_k$

For some choice of a_0, a_2, \dots, a_N integral multiples of λ , define an $(N+1) \times (N+1)$ matrix

$$\underline{A}_N = \begin{bmatrix} a_0 & xy & a_2 & 0 & a_4 & 0 & \dots & 0 & a_N \\ 1/xy & & & & & & & & \\ a_2 & & & & & & & & \\ 0 & & & & & & & & \\ a_4 & & & & A_N & & & & \\ 0 & & & & & & & & \\ \vdots & & & & & & & & \\ 0 & & & & & & & & \\ a_N & & & & & & & & \end{bmatrix}$$

using the preceding lemma to expand by the top row gives:

$$\det \underline{A}_N = (-1)^{N/2} a_0 + \sum_{k=1}^{N/2} (-1)^{(N/2)-k} a_{2k} (x^{r_{2k}} y^{s_{2k}} + x^{-r_{2k}} y^{-s_{2k}})$$

By suitably choosing α_i, β_i and a_i this determinant can be any $h \in \Lambda_{\text{sym}}^{\text{even}}$.

4.9 Lemma

Given an A_N , there is a C-complex for the simple link of linking number 1 such that, using a suitable basis,

$$A_N = (xyA + (1/xy)A' - (x/y)B - (y/x)B')$$

Proof: The C-complex is built up by starting with the standard C-complex and iteratively replacing the end clasp in the C-complex by 3 clasps.

Without loss we suppose the end clasps to be:

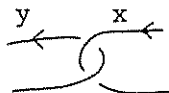

Figs (i) to (iv) show 4 possible substitutions together with the extra basis elements which produce the necessary matrix enlargements. The clasp in the box in each case is the new end clasp.

(i)

$$A/B = \begin{bmatrix} \alpha & \beta & \gamma \\ * & 0 & 0 \\ 0/-1 & 0 & 0 \\ 0 & 1/0 & 0 \end{bmatrix} \text{ gives } \begin{bmatrix} * & y/x & 0 \\ x/y & 0 & 1/xy \\ 0 & xy & 0 \end{bmatrix}$$

(ii)

$$\begin{bmatrix} * & 0 & 0 \\ 0/-1 & 0 & 1/0 \\ 0 & 0 & 0 \end{bmatrix} \text{ gives } \begin{bmatrix} * & y/x & 0 \\ x/y & 0 & xy \\ 0 & 1/xy & 0 \end{bmatrix}$$

(iii)

$$\begin{bmatrix} * & 0/-1 & 0 \\ 0 & 0 & 1/0 \\ 0 & 0 & 0 \end{bmatrix} \text{ gives } \begin{bmatrix} * & x/y & 0 \\ y/x & 0 & xy \\ 0 & 1/xy & 0 \end{bmatrix}$$

(iv)

$$\begin{bmatrix} * & 0/-1 & 0 \\ 0 & 0 & 0 \\ 0 & 1/0 & 0 \end{bmatrix} \text{ gives } \begin{bmatrix} * & x/y & 0 \\ y/x & 0 & 1/xy \\ 0 & xy & 0 \end{bmatrix}$$

4.10 Theorem

Given $\ell \geq 0$ and $h \in \Lambda_{\text{sym}}^{\text{even}}$ there is a pure link with potential

$$\nabla = P_\ell + \lambda P_{|\ell-1|} h$$

Proof:

Case 1 $\ell \geq 2$

The pure link shown below has a matrix

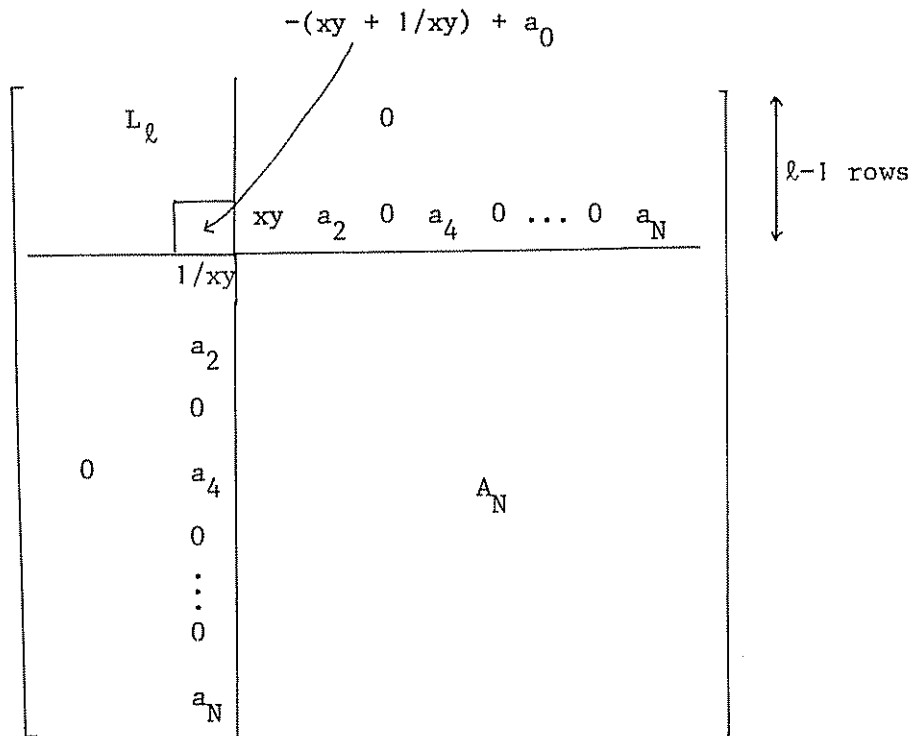

This has $\det = \det L_\ell \det A_N + \det L_{|\ell-1|} \det A_N$ which by the preceding remarks gives the result.

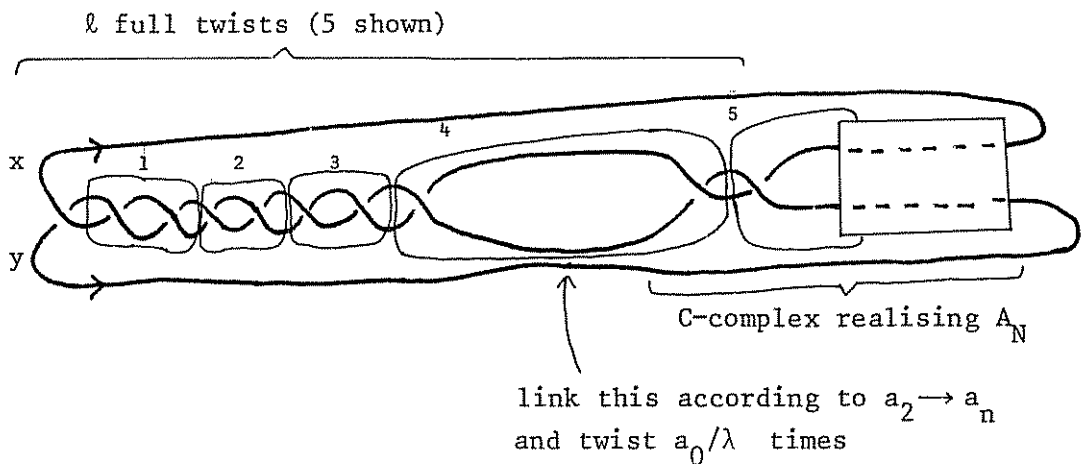

By doing the linking carefully, the y-component can be left unknotted (the numbers show part of the ordered basis of $H_1(S)$)

Case 2 $\ell = 0$

By the above technique, \underline{A}_{-N} can be realised by a pure link with linking number zero.

Case 3 $\ell = 1$

In this case $P_0 = 0$, so the result reduces to asking for $\nabla = P_1$ which is realised by the simple link, completing the proof of the theorem.

4.11 Corollary

The Torres conditions are sufficient for a polynomial to be a link polynomial when $\ell = 0$ or 2 , and in addition both components are unknotted.

This follows from the theorem on noting that $P_1 = 1$.

4.12 Proposition

Given $\ell \geq 2$, and $h_1, h_2 \in \Lambda_{\text{sym}}^{\text{even}}$ there is a link with potential

$$\nabla = P_\ell + \lambda P_{\ell-1}(h_1+h_2) + \lambda^2 P_{\ell-2} h_1 h_2$$

Proof: The matrix below can be realised using the idea in the proof of 4.10

$$\left[\begin{array}{ccc|ccc} & & & b_{N_1} & & \\ & & & \vdots & & 0 \\ & A_{N_1} & & & & \\ \hline & & & xy & & \\ b_{N_1} \dots 1/xy & & & \boxed{L_\ell} & & \\ & & & & xy \dots & a_{N_2} \\ & & & 1/xy & & \\ & 0 & & \vdots & & \\ & & & \vdots & & A_{N_2} \\ & & & a_{N_2} & & \end{array} \right]$$

then $h_i = \det \underline{A}_{-N_i}$ for $i = 1, 2$. Further details are left to the reader.

4.13 Proposition

Given $\ell \geq 2$ and for ℓ odd/even $h \in \Lambda_{\text{sym}}^{\text{odd/even}}$ there is a link having potential

$$\nabla = P_\ell + \lambda h + \lambda^2 g P_{\ell-2}$$

for some $g \in \Lambda_{\text{sym}}^{\text{even}}$

Proof: $\ell = 2$ is dealt with by (4.10), so we assume $\ell \geq 3$. The matrix shown below is realised by the C-complex indicated.

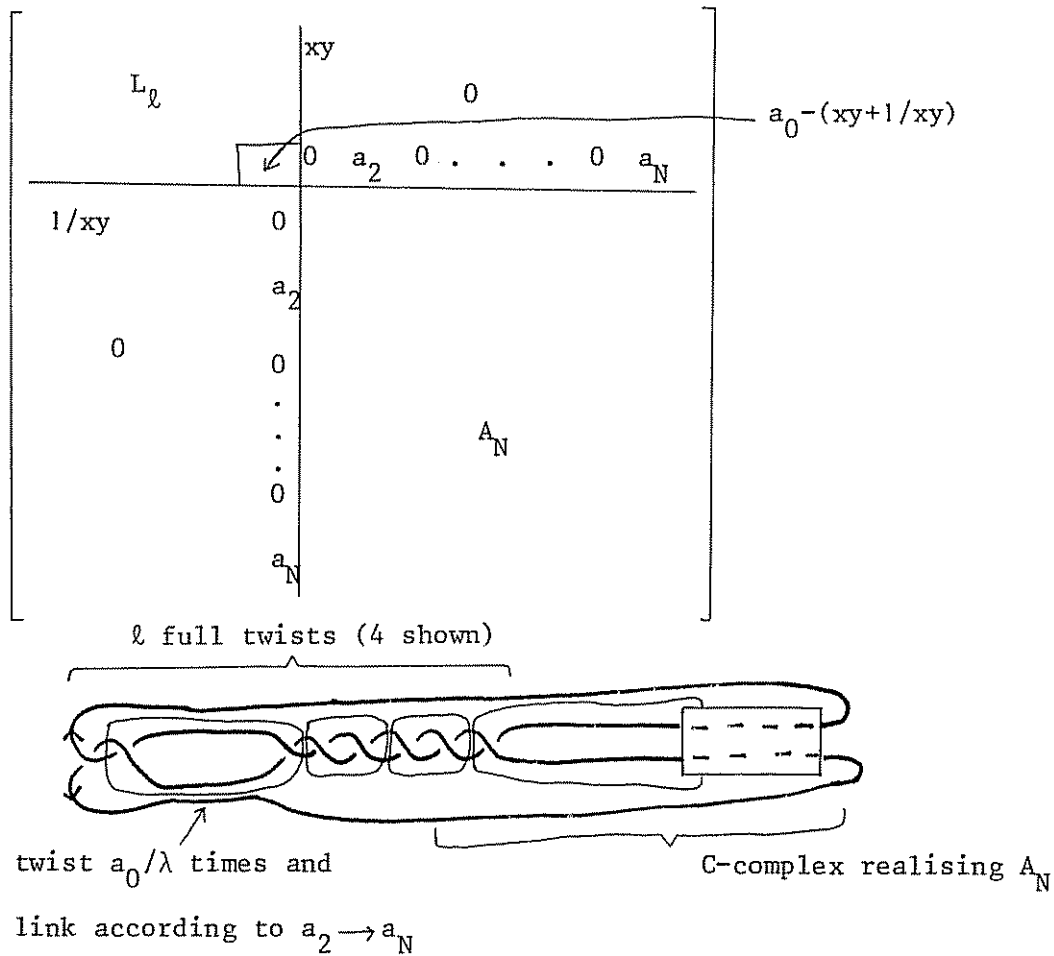

We will omit further details beyond commenting that in the evaluation of the determinant, the standard matrix for the simple link appears with the first row and last column omitted, and this matrix is upper triangular. g consists of terms quadratic in the a_i .

4.14 Remark

Bailey's presentation (B) of $H_1(\tilde{X})$ makes it clear that

$$P_\ell + \lambda P_\ell h \qquad h \in \Lambda_{\text{sym}}^{\text{odd}}$$

is realisable (in contrast to 4.7). In (B) it is noted that if

$h \in \Lambda_{\text{sym}}^{\text{odd}}$ there are $h_1 \in \Lambda_{\text{sym}}^{\text{odd}}$ $h_2 \in \Lambda_{\text{sym}}^{\text{even}}$ with

$$h = P_\ell h_1 + P_{\ell-1} h_2 \qquad \text{when } \ell \text{ is odd}$$

and a similar result when ℓ is even. So it would seem plausible that the Torres conditions are sufficient for pure links.

§5 Cobordism Invariance of Polychrome Signature

In this section an elementary proof is given of the properties of σ and τ given in (2.4). The proof of invariance is based on an examination of how one C-complex for a link may be transformed into any other C-complex for the link, and is a generalisation of a proof in the knot case where Seifert surfaces may be transformed into one another by adding and removing hollow handles (Chap 1, 2.7). Fundamental to this proof is the Isotopy lemma which gives a pair of elementary ambient isotopies of the components of a C-complex from which an arbitrary isotopy can be built up. The proof of cobordism invariance based on ribbon links does not seem to extend to links in homology spheres bounding homology 4-balls. However a separate proof of cobordism invariance based on the G-Signature theorem is given in §6 which does apply in this more general setting.

5.1 The Isotopy Lemma

Suppose that $S = V_x \cup V_y$ and $S' = V'_x \cup V'_y$ are C-complexes for a link and that V_x is ambient isotopic rel ∂V_x to V'_x and V_y is ambient isotopic rel ∂V_y to V'_y . Then S may be transformed into S' by a sequence of the following operations and their inverses:

- (I0) Ambient isotopy of S rel ∂S .
- (I1) Add a ribbon intersection between V_x and V_y (see Fig 5.1)
- (I2) Push in along an arc to convert a ribbon intersection into two clasps.

Fig 5.1

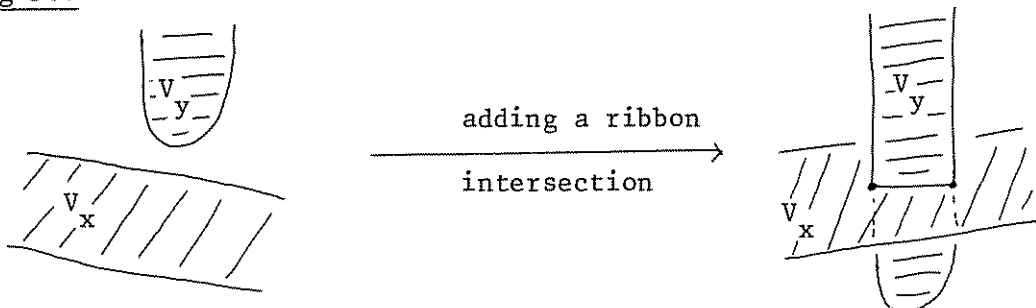

or same thing with x and y interchanged

First a preliminary:

5.2 Lemma

With the hypotheses of (5.1) there are other such ambient isotopies with V_x and V_y transverse throughout the isotopy except at a finite number of points, each of which occurs at a different 'time'.

Proof: By doing the isotopy of one of the surfaces before that of the other it suffices to consider the case in which one of the surfaces remains fixed. The track of the isotopy $f_x: V_x \times I, \partial V_x \times I \rightarrow S^3 \times I, \partial V_x \times I$ is transverse to $V_y \times I$ along $f_x(\partial(V_x \times I))$, so make $f_x(V_x \times I)$ transverse to $V_y \times I$ keeping $\partial(V_x \times I)$ fixed. Let $f_x^1 =$ new embedding $V_x \times I \rightarrow S^3 \times I$ (no longer level preserving). Take a triangulation of $S^3 \times I$ and $V_x \times I$ with $V_y \times I$ a subcomplex and f_x^1 simplicial. Now perturb those vertices of $S^3 \times I$ not on the 0- or 1- level so that no two vertices are on the same level. This can be done keeping $f_x^1(V_x \times I)$ and $V_y \times I$ transverse, indeed it suffices to show that perturbing one vertex, v say, preserves transversality. This alters $\text{star}(v)$ only, and making use of the simplicial homeomorphism $v * \text{link}(v) \rightarrow v' * \text{link}(v)$ where v' is the new position, it is clear that transversality is maintained inside $\text{star}(v)$. Call the resulting pl homeomorphism $f_x^2: V_x \times I \rightarrow S^3 \times I$. By transversality $E = f_x^2(V_x \times I) \cap (V_y \times I)$ is a 2-manifold (with boundary) and E is transverse to $S^3 \times t$ except at vertices of the triangulation. To regain level preservation, define f_x^3 by the following commutative diagram of pl maps

$$\begin{array}{ccccc}
 V_x \times I & \xrightarrow{\text{id} \times f_x^2} & V_x \times (S^3 \times I) & \xrightarrow{\text{proj}} & S^3 \times I \\
 \downarrow \cong & & \downarrow \text{proj} & & \uparrow f_x^3 \text{ : level preserving} \\
 V_x \times I & & V_x \times I & &
 \end{array}$$

$f_x^3(V_x \times I) = f_x^2(V_x \times I)$ hence $f_x^3(V_x \times t)$ is transverse to $V_y \times t$ except at finitely many points, and f_x^3 is the required map, completing the proof.

Proof of (5.1): we assume an isotopy with finitely many critical points as given by the preceding lemma. The proof will employ the idea of pushing in along a wandering arc, that is an embedding:

$$p_\alpha : V_x \times I \longrightarrow V_x \times I$$

such that $p_\alpha|_{V_x \times t}$ is a push along an arc $\alpha_t : I \longrightarrow V_x$. The effect of this is to squash the isotopy sideways to get the critical points into the desired form, and $V_x \cap V_y$ becomes a subset of the original (for all t).

Consider a critical point c lying in the interior of both V_x and V_y choose an arc α from ∂V_x to c and push in along α just before c appears then remove the push-in just after c would have appeared. In this way c is removed at the expense of additional boundary critical points (ie lying on ∂V_x or ∂V_y)

Example (movie of $V_x \cap V_y$)

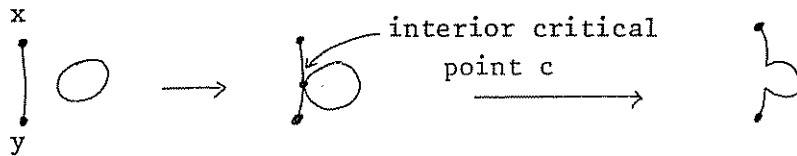

becomes (\times denotes a boundary critical point)

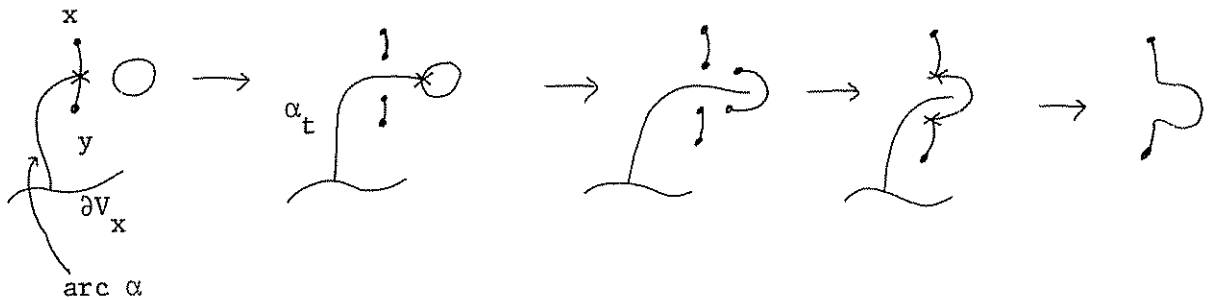

Here is a list of the possible types of boundary critical points (up to interchange of x and y , and time reversal which is indicated by a $-$ sign)

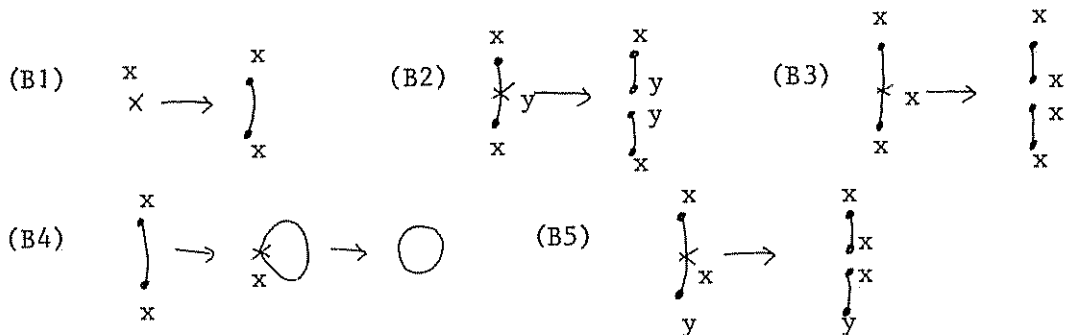

The idea is to convert everything to B1 and B2.

Step 1 Convert B4 to (lots of) B3

A circle is born by B4 and dies by -B4. Push in V_x along an arc to the circle just before birth and keep the arc breaking the circle during the lifetime of the circle. However if a point of $(\partial V_y) \cap V_x$ approaches this arc (which would cause ∂V_y to pass through ∂V_x) push in along another arc in V_x just before impact, and withdraw the original arc. In this way the circle can be kept broken until it dies.

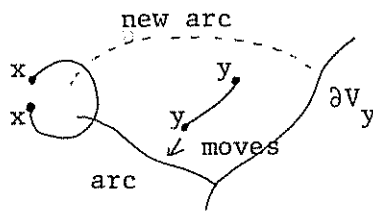

Step 2 Convert B3 to B2 + B5 + (-B2)

Push in along an arc in V_y just before the critical point and remove the push-in just after.

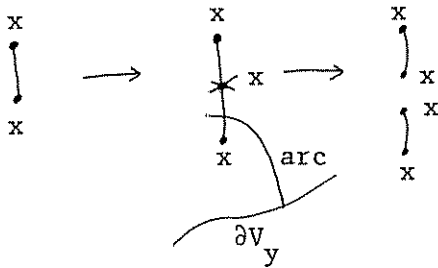

becomes:

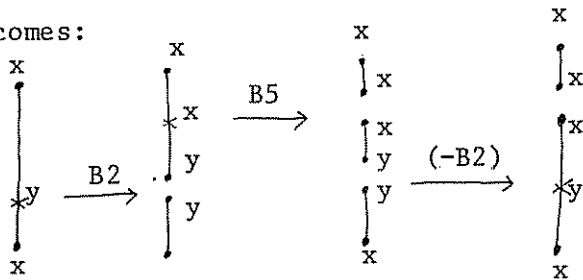

Step 3 Convert B5 to B1 + B2 + (-B2)

Push in along a wandering arc in V_y which travels along the component of $V_x \cap V_y$ in which the critical point appears, and then make the arc bulge sideways before the critical point appears.

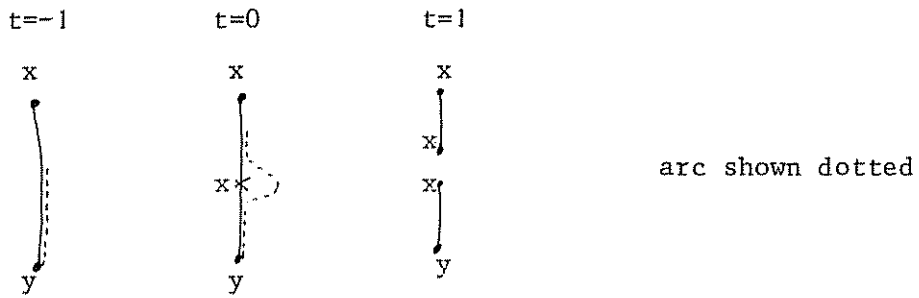

becomes:

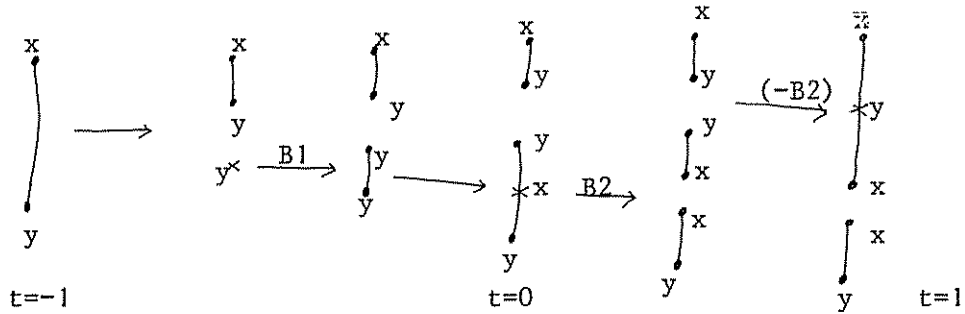

This completes the proof of the Isotopy lemma.

By (2.7) in chapter 1, any two Seifert surfaces for a knot are the same after adding hollow handles and disjoint 2-spheres. In fact the 2-spheres can be cancelled with 1-handles, leaving just the latter. Combining this with the isotopy lemma gives:

5.3 Proposition

Given two C-complexes for a link, they may be transformed into the same C-complex by a sequence of the following

- (I0) Ambient isotopy of entire C-complex
- (I1) Add a ribbon intersection
- (I2) Convert a ribbon intersection into two clasps by pushing along an arc
- (H) Add a hollow handle to V_x disjoint from V_y , or to V_y disjoint from V_x .

5.4 Definition

Let F be an RC-complex, and choose a ribbon intersection r in F . Remove from F a small disc centred on the mid point of r , and lying in the component surface of F in which the endpoints of r are interior points, see Fig (5.2). Let S be a C-complex obtained from F by the above construction at each ribbon intersection of F , then S is said to be obtained by puncturing F . The linking forms α, β for S are uniquely determined by F .

Let F be an RC-complex, and F^1 an RC-complex obtained from F by pushing in along an arc α in F to convert some ribbon intersection into two clasps. Let S be a C-complex obtained by puncturing F , and S^1 a C-complex obtained by puncturing F^1 , we may suppose that $S^1 = S \cap F^1$. Choose a standard neighbourhood U of α in S of the form shown in Fig (5.3). Pick loops e_1, \dots, e_n representing a basis of $H_1(S)$ such that e_i misses U for $i > 4$ and $e_i \cap U$ is as shown in Fig (5.3) for $i \leq 4$.

Fig 5.2

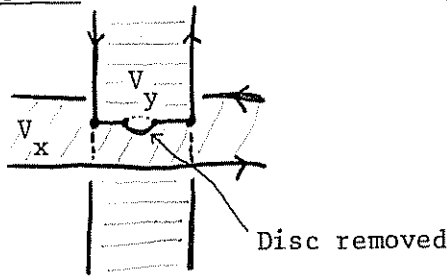
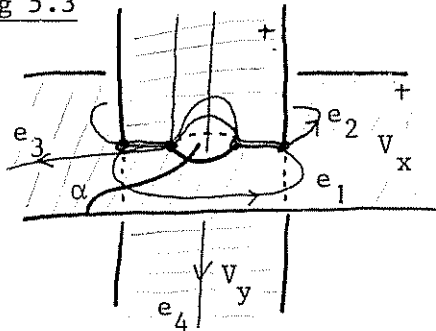

Fig 5.3



The loops e_2, \dots, e_n represent a basis of $H_1(S^1)$. The matrix $(1 + \bar{\omega}_1 \bar{\omega}_2)(\omega_1 \omega_2 A + A' - \omega_1 B - \omega_2 B')$ for S using this basis is:

$$Q = \begin{bmatrix} 0 & 0 & \theta & \phi & 0 & \dots \\ 0 & 0 & -\bar{\omega}_2 \theta & -\bar{\omega}_2 \phi & 0 & \dots \\ \bar{\theta} & -\omega_2 \bar{\theta} & & & & \\ \bar{\phi} & -\omega_2 \bar{\phi} & & & & \\ 0 & 0 & & & & \\ \vdots & \vdots & & & & \end{bmatrix} \quad \begin{aligned} \theta &= \bar{\omega}_1 + \omega_2 \\ \phi &= (1 - \omega_1) \theta \end{aligned}$$

Q_1 is the matrix obtained from Q by omitting the first row and column, thus Q_1 is the corresponding matrix for S^1 . Then it is seen from the matrix Q that:

$$\text{signature}(Q) = \text{signature}(Q_1)$$

$$\text{and} \quad \text{nullity}(Q) = \text{nullity}(Q_1) + 1$$

We may therefore use an RC-complex for calculating signature and nullity for a link, and the above shows that converting a ribbon intersection into two clasps does not change σ .

In order to complete the proof of the independence of σ and n from choice of C-complex used, by (5.3) it suffices to consider the effect of:

(I1) Add a ribbon intersection

(H_x) Add a hollow handle to V_x

(H_y) Add a hollow handle to V_y

In each case the result is an enlargement of Q of the form :

$$\begin{bmatrix} \begin{array}{c|c} Q & \begin{array}{c} \downarrow \\ v \end{array} \\ \hline \begin{array}{c} \leftarrow v^\dagger \rightarrow \end{array} & \begin{array}{c} \downarrow \\ w \end{array} \end{array} & \begin{array}{c} 0 \\ w \\ 0 \end{array} \\ \hline \hat{0} & \bar{w} & 0 \end{bmatrix}$$

where v is a complex column matrix, v^\dagger it's conjugate transpose and

for (I1) w or $\bar{w} = (1+\omega_1\omega_2)$ or $(\omega_1 + \bar{\omega}_2)$

(H_x) w or $\bar{w} = |1+\omega_1\omega_2|^2(1-\omega_2)$

(H_y) w or $\bar{w} = |1+\omega_1\omega_2|^2(1-\omega_1)$

Thus σ and n are invariants of the link provided $w \neq 0$ in any of the above, thus proving (2.4)i.

5.5 Definition

Suppose that D_x and D_y are two 2-discs immersed in S^3 without triple points, with $\partial D_x \cap \partial D_y = \emptyset$, and such that the only intersections both self and mutual are of ribbon type. Then $(\partial D_x, \partial D_y)$ is a ribbon link.

Fig 5.4

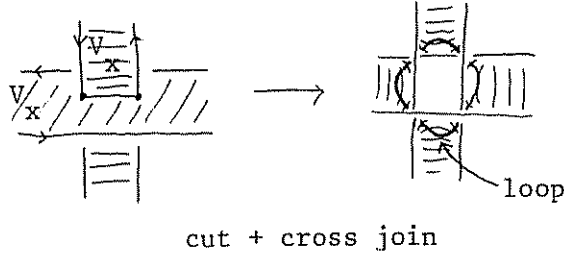
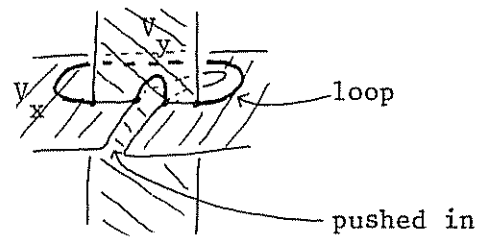

Fig 5.5



The self intersections of each disc can be modified to produce orientable surfaces by cutting and cross joining at the intersections as shown in Fig (5.4). Call the surfaces so obtained V_x and V_y , then $F = V_x \cup V_y$ is an R-complex for L, push in along some arcs to get a C-complex S. Now pick loops on S representing an ordered basis of $H_1(S)$ as follows:

- (1) For each self intersection of D_x pick a loop going round that intersection-cut-open in V_x as shown in Fig (5.4)
- (2) Do the same for V_y .
- (3) For each ribbon intersection of F, pick a loop in S going through the two resulting clasps in S as shown in Fig (5.5)
- (4) Complete the basis by picking a further n loops.

The rank of $H_1(S)$ is readily verified as $2n+1$, and the matrices A and B of the linking forms on S using this basis have the shape:

$$\text{Thus } (1+(1/xy))(xyA + A' - xB - yB') = \begin{bmatrix} 0 & G \\ \bar{G}' & * \end{bmatrix}$$

where G is an $(n+1) \times n$ matrix over Λ and $\bar{}$ is the involution of Λ sending x to $1/x$ and y to $1/y$. By (3.7) the nullity of this matrix = $\beta(L) = 1$. Let $g_i \in \Lambda$ be the determinant of the matrix obtained from G by deleting the i 'th row of G . Then the Alexander polynomial is

$$\Delta = \text{hcf}\{g_i \cdot \bar{g}_j\}_{1 \leq i, j \leq n+1} \det J (1+(1/xy))^{-2n}$$

using the fact that Λ is a unique factorisation domain to factorise the g_i 's we see that $\text{hcf}\{g_i \cdot \bar{g}_j\} = \text{hcf}\{g_i\} \cdot \text{hcf}\{\bar{g}_j\}$ from which it follows that $\Delta = F(x,y) \cdot F(x^{-1}, y^{-1})$ and $F(1,1) = 1$ (by 3.8) proving (2.3) for ribbon links.

Choose one of the $g_i \neq 0$ and call it g , then $g(\omega_1, \omega_2) \neq 0$ implies that $\sigma(\omega_1, \omega_2) = 0$ (because of the shape of the matrix) and the following lemma allows us to conclude that $\tau(\omega_1, \omega_2) = 0$ for all ω_1, ω_2 .

5.6 Lemma

If $0 \neq g \in \Lambda$ and $Z = \{(\omega_1, \omega_2) \in S^1 \times S^1 : g(\omega_1, \omega_2) = 0\}$

then $\lim_{\delta \rightarrow 0^+} \frac{1}{\delta^2} \text{measure}\{Z \cap \{(\omega'_1, \omega'_2) : |\omega_1 - \omega'_1| + |\omega_2 - \omega'_2| < \delta\}\} = 0$

for all ω_1, ω_2 .

Proof: Since $g(x,y) \in \Lambda$, $f(\theta, \phi) = g(e^{i\theta}, e^{i\phi})$ is an analytic function of $\theta, \phi \in \mathbb{R}$. Expand f about θ_1, ϕ_1 as $\sum b_{rs} (\theta - \theta_1)^r (\phi - \phi_1)^s$. If $b_{00} \neq 0$ then $g(e^{i\theta_1}, e^{i\phi_2}) \neq 0$ and continuity of g gives the result. Otherwise set $d = \min\{r+s : b_{rs} \neq 0\}$ and define $\bar{f}(\theta, \phi) = \sum_{r+s=d} b_{rs} (\theta - \theta_1)^r (\phi - \phi_1)^s$

This is homogeneous and so the zeroes of \bar{f} are a finite set of straight lines through (θ_1, ϕ_1) . A simple argument now establishes that the zeroes of f at θ_1, ϕ_1 lying within a distance of δ are within an angular distance of $K\delta$ from one of the lines of zeroes of \bar{f} (K a constant).

This proves the lemma.

5.7 Definition

Suppose L is a link of n components in S^3 , a band b is a locally flat embedding $b: I \times I \rightarrow S^3$ with $b(I \times I) \cap L = b(I \times \partial I)$. The link $L' = L - b(I \times \partial I) + b(\partial I \times I)$ is said to be obtained from L by a band move.

Example

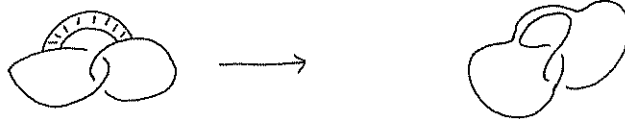

A reference for the following is (T).

A band move is allowed if $b(I \times 0)$ and $b(I \times 1)$ are contained in the same component. A link is ribbon if and only if it may be transformed using allowed band moves into a collection of unknotted circles separated from each other by disjoint 2-spheres. A band move between components k_1 and k_2 where k_2 is an unknot separated from all the other components of L by a 2-sphere is called bandsumming an unknot. A link is (strongly) slice if and only if after bandsumming some collection of unknots it becomes a ribbon link. If there are disjoint locally flat concordances from the components of a link L_0 to the components of a link L_1 , then there is a link L_2 obtainable from both L_1 and from L_0 by bandsumming unknots.

5.8 Theorem

If there are locally flat disjoint concordances from the two components of L to those of L' , then :

$$\beta(L) = \beta(L')$$

$$\Delta_L F \bar{F} \triangleq \Delta_{L'} F' \bar{F}' \quad \text{for some } F, F' \in \Lambda \text{ with } F(1,1) = 1 = F'(1,1)$$

$$\text{and } \tau(\omega_1, \omega_2, L) = \tau(\omega_1, \omega_2, L') \quad \text{for all } \omega_1, \omega_2$$

{ This theorem for n -component links is due to Kawauchi and Nakagawa, except for the signature part }

From the above discussion it suffices to prove the theorem when L' is obtained from L by bandsumming an unknot onto one of the components of L . Choose a C -complex S for L and a disjoint disc D spanning the unknot U , such that $(S \cup D)$ is transverse to $\text{int } b(I \times I)$ and all intersections between them are of ribbon type. From the RC -complex $S \cup D \cup b(I \times I)$ form a C -complex S' for L' by pushing along arcs and cutting + cross joining self intersections as before. If A, B are the linking matrices of S using some basis of $H_1(S)$, this basis may be extended to one for $H_1(S')$ by picking one loop running round each pair of clasps arising from the ribbon intersections, and further loops from the cross joined self intersections {as when dealing with ribbon links} making a total of n say, then a further n loops are required to complete the basis. The linking matrices A_1 and B_1 for S' using this basis are of the shape:

$$A_1 = \begin{bmatrix} 0 & C & 0 \\ D & * & * \\ 0 & * & A \end{bmatrix} \quad B_1 = \begin{bmatrix} 0 & E & 0 \\ F & * & * \\ 0 & * & B \end{bmatrix}$$

where C, D, E, F are $n \times n$ matrices (over \mathbb{Z}).

Set $\ell = \text{Lk}(L_x, L_y) = \text{Lk}(L'_x, L'_y)$, then by (3.6 ii) $\Delta_{L'}(1, 1) = \ell$ thus if $\ell \neq 0$ then $F(x, y) = \det(xyC + D' - xE - yF') \neq 0$. If however, $\ell = 0$, then remove one of the clasps from S (and from S') this reduces A, B (and A_1, B_1) by a row and column and makes $\ell = \pm 1$, which by the previous argument shows $F(x, y) \neq 0$. It follows that

$\beta(L) = \beta(L') = \text{nullity}(xyA + A' - xB - yB')$. If $\beta(L) = 0$ then:

$$\Delta_{L'}(x, y) = F(x, y) \cdot F(x^{-1}, y^{-1}) \cdot \Delta_L(x, y)$$

and $F(\omega_1, \omega_2) \neq 0$ implies that $\sigma(\omega_1, \omega_2, L) = \sigma(\omega_1, \omega_2, L')$

which by (5.6) implies that $\tau(\omega_1, \omega_2, L) = \tau(\omega_1, \omega_2, L')$ for all ω_1, ω_2

thus proving (5.8) when $\beta(L) = 0$.

This leaves the case $\beta(L) = 1$, define:

$$N = (1+(1/xy))(xyC + D' - xE - yF')$$

$$M = (1+(1/xy))(xyA + A' - xB - yB')$$

$$M_1 = (1+(1/xy))(xyA_1 + A'_1 - xB_1 - yB'_1)$$

then

$$M_1 = \begin{bmatrix} 0 & N & 0 \\ \bar{N}' & * & * \\ 0 & * & M \end{bmatrix} \begin{array}{l} \uparrow \\ p \text{ rows} \\ \downarrow \end{array}$$

define $\Lambda_{(y)} = \Lambda \otimes Q(y)$. Then nullity(M) = 1, and $\Lambda_{(y)}$ is a PID so there is $R \in GL(\Lambda_{(y)})$ having the same size as M such that

$$RM = \begin{bmatrix} M_2 \\ \text{---}0\text{---} \end{bmatrix}$$

therefore

$$RM\bar{R}' = \begin{bmatrix} M_2 & 1 \\ \text{---}0\text{---} & 1 \end{bmatrix}$$

and $\det M_2 \neq 0$. It follows that there is $R_1 \in GL(\Lambda_{(y)})$ with

$$R_1 M_1 \bar{R}'_1 = \begin{bmatrix} 0 & N_1 & 0 & | & \\ \bar{N}'_1 & * & * & | & 0 \\ 0 & * & M_2 & | & \\ \text{---}0\text{---} & & & | & \end{bmatrix}$$

The ideal of $\Lambda_{(y)}$ generated by the (p-1) minors of M_1 and that generated by the (p-1) minors of $R_1 M_1 \bar{R}'_1$ are the same and are generated by $\det N_1 \cdot \det \bar{N}'_1 \cdot \det M_2$. Thus:

$$\Delta_{L'}(x,y) = \det N_1 \cdot \det \bar{N}'_1 \cdot \det M_2 \cdot u \quad \text{for some unit } u \in \Lambda_{(y)}$$

$$\text{also } \Delta_L(x,y) = \det M_2 \cdot u_1 \quad \text{for some unit } u_1 \in \Lambda_{(y)}$$

$$\text{and so } \Delta_{L'}(x,y) / \Delta_L(x,y) = F_1(x,y) \cdot F_1(\bar{x}, \bar{y}) \cdot u_2 \quad \text{unit } u_2 = u/u_1$$

where $F_1(x,y) = \det N_1$. A unit in $\Lambda_{(y)}$ is of the form $x^r f_1(y) / g_1(y)$

and by doing the above with $\Lambda_{(x)}$ in place of $\Lambda_{(y)}$ the same result is

obtained, but with a unit in $\Lambda_{(x)}$ of the form $y^s f_2(x) / g_2(x)$.

using that Λ is a unique factorisation domain to decompose all the factors into irreducibles, and comparing these expressions we get

$$\text{that: } \frac{f_1(y)}{g_1(y)} = \frac{f'_1(y) \cdot f'_1(y^{-1})}{g'_1(y) \cdot g'_1(y^{-1})}$$

$$\frac{f_2(x)}{g_2(x)} = \frac{f'_2(x) \cdot f'_2(x^{-1})}{g'_2(x) \cdot g'_2(x^{-1})}$$

and so $\Delta_{L'}(x,y) = F(x,y) \cdot F(x^{-1}, y^{-1}) \cdot \Delta_L(x,y)$ up to units in Λ .

Define $f(x,y) = \det N_1 \cdot \det R_1 \in \Lambda(y)$ then $f(\omega_1, \omega_2) \neq 0$ implies

$\sigma(\omega_1, \omega_2, L) = \sigma(\omega_1, \omega_2, L')$ which by (5.6) implies that

$\tau(\omega_1, \omega_2, L) = \tau(\omega_1, \omega_2, L')$ for all ω_1, ω_2 . This completes the proof of (5.8) and (2.3) and (2.4).

5.9 Remark

There exist links L for which $\sigma(\omega, L) = 0$ for all ω but for which $\sigma(\omega_1, \omega_2, L) \neq 0$ for some ω_1, ω_2 . Indeed if k is any knot for which $\sigma(\omega, k) \neq 0$ for some ω , then a split link L comprising of k and $(-k)$ has $\sigma(\omega, L) = 0$, and $\sigma(\omega_1, \omega_2, L) = \sigma(\omega_1, k) - \sigma(\omega_2, k)$.

§6 Interpretation of Polychrome signatures in terms of G-signatures

The modern view of the knot signature $\sigma(\omega, k)$ runs as follows (V), (G p35). Given a knot k in S^3 , push the interior of a Seifert surface V for k into the interior of B^4 . Form the p -fold cover \tilde{X} of B^4 branched over V . Then $H_2(\tilde{X}; \mathbb{C})$ has an automorphism τ , of period p , and so decomposes into τ -invariant eigenspaces $E^0 \oplus E^1 \oplus \dots \oplus E^{p-1}$ corresponding to eigenvalues $\xi^0, \xi^1, \dots, \xi^{p-1}$ where $\xi = e^{2\pi i/p}$ (τ is the canonical automorphism in the sense of §4, chap 1). The Hermitian intersection pairing is an inner product with respect to which τ is an isometry and the decomposition is orthogonal. One finds that

$$\sigma_{r/p} \equiv \sigma(\cdot | E^r) = \sigma(1 - \xi^r)(A - \bar{\xi}^r A') \equiv \sigma(\xi^r, k)$$

where A is a Seifert matrix for V , and $0 \leq r < p$.

The automorphism τ of \tilde{X} gives rise to a g -signature (AS) as follows. τ is an isometry of $H_2(\tilde{X}; \mathbb{R})$ which decomposes into τ -invariant subspaces H^+, H^-, H^0 on which the intersection pairing is $+, -$ definite and zero respectively. The g -signature arising from τ^r is

$$\sigma(\tau^r) = \text{Trace}(\tau^r | H^+) - \text{Trace}(\tau^r | H^-).$$

The g -signature theorem says that for closed manifolds, $\sigma(\tau^r)$ depends only on the action of τ^r on the normal bundle of it's fixed point set. Decomposing each E^r into subspaces on which the intersection pairing is \pm definite and zero respectively, we see that

$$\sigma(\tau^s) = \sum_{r=0}^{p-1} \xi^{sr} \sigma_{r/p} \quad \text{for } 0 \leq s < p$$

The matrix $A_{sr} = \xi^{sr}$ is non-singular, and so the equations may be inverted expressing $\sigma_{r/p}$ in terms of g -signatures $\sigma(\tau^s)$.

If V_1 and V_2 are two Seifert surfaces for k , then \tilde{X}_1 and \tilde{X}_2 have the same τ -action on their boundary (=cyclic cover of S^3 branched over k) and so \tilde{X}_1 and \tilde{X}_2 may be glued equivariantly along their boundary to produce a closed manifold Y . If $r > 0$ then τ^r acting on Y has fixed

point set $V_1 \cup V_2$, and the self intersection number of this surface in Y is zero, which by the g -signature theorem implies that $\sigma(\tau^r) = 0$. For $r = 0$ the g -signature is just the ordinary signature of Y , which is zero, thus all g -signatures are zero. Equivariant Novikov additivity now implies that the g -signatures of \tilde{X}_1 and \tilde{X}_2 are all the same, and so the eigenspace signatures (and so $\sigma(\omega, k)$) do not depend on the Seifert surface chosen for k .

Now suppose that k is slice, then there is a smooth disc D properly embedded in B^4 with $\partial D = k$, Let $X = B^4 - D$, then X is an homology circle, and so by a result of Milnor, \tilde{X}_p , the p -fold cyclic cover of B^4 branched over D , is a rational homology ball (for prime p), hence $\sigma_{r/p} = 0$, thus $\sigma(\xi^r, k) = 0$ when ξ is a p 'th root of unity. Since these points are dense in the unit circle, $\tau(\omega, k) = 0$ for all ω if k is slice.

Following a suggestion of Casson and Lickorish, this view will now be applied to polychrome signatures, resulting (eventually) in another proof of their cobordism invariance, however this method of proof does not give the result on the Alexander polynomial. An advantage of the present proof is that it applies to links in \mathbb{Z} -homology spheres, showing that signature vanishes for links slice in any homology 4-ball.

Suppose that $S = V_x \cup V_y$ is a C -complex for a link L in S^3 , push $\text{int}(V_x)$ and $\text{int}(V_y)$ into $\text{int}(B^4)$, this may be done so that V_x and V_y are disjoint except at a finite number of points, one for each clasp, where they intersect transversely. In the rest of this section we will denote these isotoped versions by V_x and V_y . If A is a subcomplex of B^4 we write $N(A)$ for a regular neighbourhood of A in B^4 which meets ∂B^4 regularly. Define $N = N(V_x \cup V_y)$ and $X = \text{cl}(B^4 - N)$, by duality $H_1(X) \cong H_2(V_x \cup V_y, L_x \cup L_y) \cong 2\mathbb{Z}$.

Let $p: \tilde{X} \rightarrow X$ be the $Z_r \oplus Z_s$ cover of X (unbranched), and let x, y be the generators of G , the group of covering automorphisms, determined by the meridians of L_x, L_y . There is also a branched covering $p: \tilde{X}^{br} \rightarrow B^4$ with branch index r over V_x , and branch index s over V_y , G acts on \tilde{X}^{br} also. $H_2(\tilde{X}; \mathbb{C})$ decomposes under the G action into eigenspaces $E^{a,b} = E_x^a \cap E_y^b$ where E_x^a is the $e^{2\pi ia/r}$ eigenspace for x , and E_y^b is the $e^{2\pi ib/s}$ eigen space for y . $H_2(\tilde{X}^{br}; \mathbb{C})$ similarly decomposes, write $E^{a,b}(\tilde{X}^{br})$ for this eigen space.

(6.1) Proposition

If $0 < a < r$ and $0 < b < s$, and $\omega_x = e^{2\pi ia/r}$, $\omega_y = e^{2\pi ib/s}$ then $\sigma(\omega_x, \omega_y, L) = \sigma(\cdot | E^{a,b}(\tilde{X}^{br}))$

The proof of this is deferred. If now r and s are coprime then G is cyclic, generated by (xy) , and the eigen space decomposition of $H_2(\tilde{X}^{br}; \mathbb{C})$ may be re-written $\oplus E^m$ where E^m is the eigen space of (xy) with eigen value ξ^m ($\xi = e^{2\pi i/rs}$). Then, as in the knot case,

$$\sigma((xy)^k) = \sum_{j=0}^{rs-1} \xi^{jk} \sigma(\cdot | E^j) \quad 0 \leq k < rs$$

and again this may be inverted to express the eigen space signatures as linear combinations of g -signatures $\sigma((xy)^k)$. Since $E^{a,b} = E^m$ for some m this also gives an expression for $\sigma(\xi^a, \xi^b, L)$.

Suppose now that S_1 and S_2 are two C -complexes for L giving rise to \tilde{X}_1^{br} and \tilde{X}_2^{br} , then these can be glued equivariantly along their boundary (= branched cover of S^3 , branched over L_x, L_y) to produce a closed manifold $\tilde{Y}_{r,s}$. To apply the g -signature theorem, we need to look at the fixed point set of $(xy)^k$, and to this end we have a closer look at the $Z_p \oplus Z_q$ covers involved.

Define $U_x = V_{1x} \cup V_{2x}$ $U_y = V_{1y} \cup V_{2y}$ $Y = S^4$
 then the cover $p: \tilde{Y}_{rs} \longrightarrow Y$ factors

$$\tilde{Y}_{rs} \xrightarrow{p_2} \tilde{Y}_r \xrightarrow{p_1} Y$$

where p_1 is an r -fold cyclic cover of Y branched over U_x , and p_2 is an s -fold cyclic cover of \tilde{Y}_r branched over $p_1^{-1}(U_y)$. Now $p_1|_{p_1^{-1}(U_y)} \longrightarrow U_y$ is a cyclic cover of U_y branched over $U_x \cap U_y$ a finite set of points. U_y has trivial normal bundle in Y so there is a nearby disjoint copy U'_y of U_y in Y . Then $p_1^{-1}(U'_y)$ is disjoint from $p_1^{-1}(U_y)$, hence $p^{-1}(U'_y)$ is disjoint from $p^{-1}(U_y)$.

The fixed point set of $x^a y^b$ is:

- (1) \tilde{Y}_{rs} if $a = b = 0$
- (2x) $p^{-1}(U_x)$ if $a > 0, b = 0$
- (2y) $p^{-1}(U_y)$ if $b > 0, a = 0$
- (3) $p^{-1}(U_x \cap U_y)$ if $a, b > 0$

For case (1), $\sigma((xy)^0) = \sigma(\tilde{Y}_{rs}) = rs\sigma(Y) = 0$. This follows from (CG1) lemma 2.1, which implies that if $\tilde{N} \longrightarrow N$ is an m -fold cyclic cover of a closed 4-manifold N branched over a closed surface F , and $[F] \cdot [F] = 0$ then $\sigma(\tilde{N}) = m\sigma(N)$. The factorisation of p into two cyclic covers, each branched over surfaces with self intersection number zero proves the assertion.

For case (2y), the g -signature theorem says that:

$$\sigma(y^b) = [p^{-1}(U_y)]^2 \operatorname{cosec}^2(\pi b/s)$$

which is zero because the self intersection number of $p^{-1}(U_y)$ is zero by the previous discussion. Similarly for (2x).

For (3) the fixed point set is a finite set of points. The action on the normal bundle of a fixed point splits into a product of two actions each of which is a rotation about the centre of a 2-disc. The contribution to the g -signatures of each fixed point is $-\cot(\theta_1/2)\cot(\theta_2/2)$ where θ_1 and θ_2 are the angles of rotation in the two discs. Now each point

of $U_x \cap U_y$ has a sign determined by orientations, and the contribution to g -signature from oppositely oriented points cancel out. However $[U_x] \cdot [U_y] = 0$, so that all the terms cancel out.

This establishes that the g -signatures of \tilde{Y}_{rs} all vanish. Equivariant Novikov additivity implies that the g -signatures of \tilde{X}_1^{br} and \tilde{X}_2^{br} are the same, and so $\sigma(\xi^a, \xi^b, L)$ does not depend on the G -complex chosen. Such points are dense in $S^1 \times S^1$ and so $\tau(\omega_1, \omega_2, L)$ is an invariant of L for all ω_1, ω_2 . Now suppose that L is (strongly) slice:

(6.2) Proposition

If D_x and D_y are disjoint smooth discs in B^4 , and $\tilde{X}_{q,q}^{br}$ is the $Z_q \oplus Z_q$ cover of B^4 branched over D_x and D_y with index q and if q is a prime, then $H_2(\tilde{X}_{q,q}^{br}; \mathbb{Q}) = 0$

The proof of this is deferred. It follows from (6.1) that $\sigma(\omega_1, \omega_2, L) = 0$ when ω_1 and ω_2 are q 'th roots of unity other than unity. Since these points are dense in $S^1 \times S^1$ it follows that $\tau(\omega_1, \omega_2, L) = 0$ for all ω_1, ω_2 if L is slice. With a bit more work one can show that τ is an invariant of the cobordism class of L . We must now prove (6.1) and (6.2).

(6.3) Lemma

The map induced by inclusion $H_2(\tilde{X}; \mathbb{C}) \longrightarrow H_2(\tilde{X}^{br}; \mathbb{C})$ is an isomorphism of eigen spaces $E^{a,b}$ when $0 < a < r$ and $0 < b < s$.

Proof: Define $N_x = N(V_x)$ $\tilde{N}_x = p^{-1}(N_x)$
 $N_y = N(V_y)$ $\tilde{N}_y = p^{-1}(N_y)$
 $\tilde{N} = p^{-1}(N)$

the Mayer Vietoris sequence for \tilde{N}, \tilde{X} (coefficients \mathbb{C}) is :

$$\longrightarrow H_2(\tilde{N}) \oplus H_2(\tilde{X}) \longrightarrow H_2(\tilde{X}^{br}) \longrightarrow H_1(\partial\tilde{N}) \longrightarrow H_1(\tilde{N}) \oplus H_1(\tilde{X}) \longrightarrow$$

now $\tilde{N} = \tilde{N}_x \cup \tilde{N}_y$ joined along $p^{-1}(N(V_x \cap V_y))$ which is a collection of 4-balls, thus $H_2(\tilde{N}_x) \oplus H_2(\tilde{N}_y) \xrightarrow{\cong} H_2(\tilde{N})$ under inclusion. The covering $p: \tilde{N}_x \rightarrow N_x$ factors

$$\tilde{N}_x \xrightarrow{P_2} \tilde{N}_x^s \xrightarrow{P_1} N_x$$

where p_1 is an s -fold cover branched over $(V_y \cap N_x)$. Using the transversality of V_y and V_x , this cover is $B^2 \times_{p_1^{-1}}(V_x) \rightarrow B^2 \times V_x$, and $P_1|_{V_x}$ is a branched cover of V_x branched over $V_x \cap V_y$. p_2 is an r -fold cover of \tilde{N}_x^s branched over $p_1^{-1}(V_x)$ with branch index r . It is now clear that $\tilde{N}_x \cong B^2 \times p^{-1}(V_x)$ and x acts on \tilde{N}_x by rotation of the B^2 factor through $2\pi/r$. Thus $x_* = \text{id} : H_*(\tilde{N}_x) \rightarrow H_*(\tilde{N}_x)$, so the only non-zero eigen spaces of $H_2(\tilde{N}_x)$ are $E^{0,b}$. Similar remarks apply to $H_2(\tilde{N}_y)$ which has only $E^{a,0}$ eigen spaces non-zero.

The proof of the lemma will be complete if it can be shown that

Claim: the only non-zero eigen spaces of $\ker\{i_*: H_1(\partial\tilde{N}) \rightarrow H_1(\tilde{N})\}$ are $E^{a,0}$ and $E^{0,b}$.

$$\begin{aligned} \text{Define } Q_x &= N_x \cap \partial N & \tilde{Q}_x &= p^{-1}(Q_x) \\ Q_y &= N_y \cap \partial N & \tilde{Q}_y &= p^{-1}(Q_y) \end{aligned}$$

then $\tilde{N} = \tilde{Q}_x \cup \tilde{Q}_y$ joined along 2-torii, one for each point of $p^{-1}(V_x \cap V_y)$

Consider the commutative diagram below, whose rows are Mayer-Vietoris sequences, and the vertical maps are induced by inclusions

$$\begin{array}{ccccc} H_1(\tilde{Q}_x) \oplus H_1(\tilde{Q}_y) & \xrightarrow{j_*} & H_1(\partial\tilde{N}) & \longrightarrow & H_0(\tilde{Q}_x \cap \tilde{Q}_y) \\ \downarrow & & \downarrow i_* & & \downarrow k_* \\ H_1(\tilde{N}_x) \oplus H_1(\tilde{N}_y) & \longrightarrow & H_1(\tilde{N}) & \longrightarrow & H_0(\tilde{N}_x \cap \tilde{N}_y) \end{array}$$

k_* is an isomorphism because each component of $(\tilde{N}_x \cap \tilde{N}_y) \cap \partial\tilde{N}$ is a single 2-torus component of $\tilde{Q}_x \cap \tilde{Q}_y$. Thus $\ker i_* \leq \text{Im } j_*$.

The same remarks apply to the covering $p: \tilde{Q}_x \rightarrow Q_x$ as to $\tilde{N}_x \rightarrow N_x$ so that $x_* = \text{id} : H_*(\tilde{Q}_x) \rightarrow H_*(\tilde{Q}_x)$, which establishes the claim, completing the proof.

We proceed to calculate $\sigma(\cdot | E^{a,b}(\tilde{X}))$ for $0 < a < r$, $0 < b < s$, which by the lemma is also $\sigma(\cdot | E^{a,b}(\tilde{X}^{br}))$. {cf (CG1) end of proof of 3.1}

Let M_x (resp M_y) be the track of the isotopy used to push V_x (resp V_y) into B^4 , we may assume that M_x and M_y are transverse. Then $p^{-1}(M_x \cup M_y)$ separates \tilde{X} into components each of which is $C = \text{cl}(B^4 - N(M_x \cup M_y)) \cong B^4$

Define $J_x = \text{cl}(M_x - N(M_x \cup M_y)) \cong M_x$

$J_y = \text{cl}(M_y - N(M_x \cup M_y)) \cong M_y$

{ here we assume M_x and M_y chosen to have the simplest intersection round

clasps } then ∂C contains two copies J_x^\pm of J_x and two copies J_y^\pm

of J_y . Label the lifts of C as $C^{i,j}$ $0 \leq i < r$ $0 \leq j < s$ then

J_x^+ in $C^{i,j}$ is joined to J_x^- in $C^{i+1,j}$ and J_y^+ in $C^{i,j}$ is joined

to J_y^- in $C^{i,j+1}$. Now $\text{incl}_* : H_1(J_x), H_1(J_y) \rightarrow H_1(C)$ are zero, so

given a 1-cycle α on S , define 2-chains (by taking a cone from a point

in $\text{int}(C)$ to α) $a^{--}, a^{-+}, a^{+-}, a^{++} \in C_2(C)$ with $\partial a^{--} = i_{--}\alpha$ etc.

If $\{\alpha\} \in H_1(V_x)$ define $\Psi_x(\alpha) = xa^{--} - a^{++}$

$\{\alpha\} \in H_1(V_y)$ define $\Psi_y(\alpha) = ya^{--} - a^{++}$

$\{\alpha\} \in H_1(S)$ define $\Psi(\alpha) = xya^{--} + a^{++} - xa^{-+} - ya^{+-}$

Then if $\{\alpha_i\}$ is a basis of $H_1(V_x)$ and $\{\beta_j\}$ is a basis of $H_1(V_y)$

and $\{\gamma_k\}$ is a basis of $\hat{\phi}H_0(\varepsilon S)$ then it can be shown that (by a Mayer

Vietoris argument) the following is a $\mathbb{C}[Z_p \oplus Z_q]$ basis of $H_2(\tilde{X}; \mathbb{C})$

$\{\Psi_x(\alpha_i), \Psi_y(\beta_j), \Psi(\gamma_k)\}$

Define $\omega_x = e^{2\pi ia/r}$ $\omega_y = e^{2\pi ib/s}$, and given $\{\gamma\} \in H_1(S)$

$$\Psi_{a,b}(\gamma) = \sum_{u=0}^{r-1} \sum_{v=0}^{s-1} \omega_x^{-u} \omega_y^{-v} x^u y^v \Psi(\gamma)$$

(6.4) Lemma

If $0 < a < r$, $0 < b < s$, then $\{\Psi_{a,b}(\alpha_i), \Psi_{a,b}(\beta_j), \Psi_{a,b}(\gamma_k)\}$ is a basis of $E^{a,b}(\tilde{X})$.

Proof: Let $\langle \alpha \rangle$ denote the $\mathbb{C}[G]$ submodule of $H_2(\tilde{X})$ generated by α .

We claim that:

$$E^{a,b} \cap \langle \Psi_x(\alpha) \rangle = \langle \Psi_{a,b}(\alpha) \rangle \quad \text{for } \{\alpha\} \in H_1(V_x)$$

To see this, we have $\dim_{\mathbb{C}} E^{a,b} \cap \langle \Psi_x(\alpha) \rangle = 1$, and is generated by

$$\sum_{u=0}^r \sum_{v=0}^s \bar{\omega}_x^u \cdot \bar{\omega}_y^v \cdot x^u y^v \Psi_x(\alpha)$$

now $\Psi(\alpha) = y\Psi_x(\alpha) - \Psi_x(\alpha)$ (recall $i_{--}\alpha = i_{-+}\alpha$, $i_{++}\alpha = i_{+-}\alpha$)

and so:

$$\begin{aligned} \Psi_{a,b}(\alpha) &= \sum_{u=0}^r \sum_{v=0}^s \bar{\omega}_x^u \cdot \bar{\omega}_y^v \cdot x^u y^v (y\Psi_x(\alpha) - \Psi_x(\alpha)) \\ &= (\omega_y - 1) \cdot \sum_{u=0}^r \sum_{v=0}^s \bar{\omega}_x^u \cdot \bar{\omega}_y^v \cdot x^u y^v \Psi_x(\alpha) \end{aligned}$$

thus provided $(\omega_y - 1) \neq 0$ the claim is established. A similar result holds for x and y interchanged. This establishes the lemma.

We can now describe the intersection pairing on $E^{a,b}(\tilde{X})$.

$$\begin{aligned} &\Psi_{a,b}(\alpha) \cdot \Psi_{a,b}(\beta) \\ &= \sum_{i=0}^r \sum_{j=0}^s \bar{\omega}_x^i \cdot \bar{\omega}_y^j \cdot x^i y^j \Psi(\alpha) \cdot \sum_{k=0}^r \sum_{\ell=0}^s \bar{\omega}_x^k \cdot \bar{\omega}_y^{\ell} \cdot x^k y^{\ell} \Psi(\beta) \\ &= \sum_{i,k=0}^r \sum_{j,\ell=0}^s \omega_x^{(k-i)} \cdot \omega_y^{(\ell-j)} \cdot \{x^i y^j \Psi(\alpha) \cdot x^k y^{\ell} \Psi(\beta)\} \end{aligned}$$

since x and y are isometries of \cdot , it suffices to calculate

$$\Psi(\alpha) \cdot x^i y^j \Psi(\beta) \quad 0 \leq i < r, \quad 0 \leq j < s$$

{refer to Fig (3.5), cf proof of (4.2) chap 1 for the following}

$$\begin{aligned}
& \Psi(\alpha) \cdot x^i y^j \Psi(\beta) \\
= & 0 && |i| > 1 \text{ or } |j| > 1 \\
& \text{Lk}(i_{--}\alpha, \beta) && i = j = 1 \\
& -\text{Lk}(i_{--}\alpha, \beta) - \text{Lk}(i_{-+}\alpha, \beta) && i = 1, j = 0 \\
& \text{Lk}(i_{-+}\alpha, \beta) && i = 1, j = -1 \\
& -\text{Lk}(i_{+-}\alpha, \beta) - \text{Lk}(i_{--}\alpha, \beta) && i = 0, j = 1 \\
& \text{Lk}(i_{--}\alpha, \beta) + \text{Lk}(i_{-+}\alpha, \beta) + \text{Lk}(i_{+-}\alpha, \beta) + \text{Lk}(i_{++}\alpha, \beta) && i = j = 0 \\
& -\text{Lk}(i_{++}\alpha, \beta) - \text{Lk}(i_{-+}\alpha, \beta) && i = 0, j = -1 \\
& \text{Lk}(i_{+-}\alpha, \beta) && i = -1, j = 1 \\
& -\text{Lk}(i_{+-}\alpha, \beta) - \text{Lk}(i_{++}\alpha, \beta) && i = -1, j = 0 \\
& \text{Lk}(i_{++}\alpha, \beta) && i = j = -1
\end{aligned}$$

Let A, B be the linking matrices for $V_x \cup V_y$ with respect to the basis $\{\alpha_i\}$ of $H_1(S)$, then

$$\begin{aligned}
& \Psi_{a,b}(\alpha_i) \cdot \Psi_{a,b}(\alpha_j) \\
= & \omega_x \omega_y A_{ij} - \omega_x (A_{ij} + B_{ij}) + \omega_x \bar{\omega}_y B_{ij} - \omega_y (B'_{ij} + A'_{ij}) + (A_{ij} + A'_{ij} + B_{ij} + B'_{ij}) \\
& - \bar{\omega}_y (A'_{ij} + B_{ij}) + \bar{\omega}_x \omega_y B'_{ij} - \bar{\omega}_x (B'_{ij} + A'_{ij}) + \bar{\omega}_x \bar{\omega}_y A'_{ij} \\
= & A_{ij} (\omega_x \omega_y - \omega_x - \omega_y + 1) + A'_{ij} (\bar{\omega}_x \bar{\omega}_y - \bar{\omega}_x - \bar{\omega}_y + 1) \\
& + B_{ij} (-\omega_x + \omega_x \bar{\omega}_y + 1 - \bar{\omega}_y) + B'_{ij} (-\bar{\omega}_x + 1 + \bar{\omega}_x \omega_y - \omega_y)
\end{aligned}$$

set $\lambda = (\omega_x - 1)(\omega_y - 1)$, giving:

$$\begin{aligned}
& = \lambda A_{ij} + \bar{\lambda} A'_{ij} - \bar{\omega}_y \lambda B_{ij} - \omega_y \bar{\lambda} B'_{ij} \\
& = \bar{\lambda} (\lambda / \bar{\lambda}) A_{ij} + A'_{ij} - \bar{\omega}_y (\lambda / \bar{\lambda}) B_{ij} - \omega_y B'_{ij}
\end{aligned}$$

now $\lambda / \bar{\lambda} = \omega_x \omega_y$ so this gives:

$$= \bar{\lambda} (\omega_x \omega_y A_{ij} + A'_{ij} - \omega_x B_{ij} - \omega_y B'_{ij})$$

from which it is seen that $\sigma(\cdot | E^{a,b}) = \sigma(\omega_x, \omega_y, L)$ proving (6.1).

(6.5) Lemma

Suppose that $H_r(X; \mathbb{Z}_q) = 0$ for $r > 1$, where X is a finite complex and q is a prime. Then if $p: \tilde{X} \rightarrow X$ is an infinite cyclic covering, and $\tilde{X}_q \rightarrow X$ is the corresponding q -fold cyclic covering then:

$$H_r(\tilde{X}_q; \mathbb{Z}_q) = 0 \quad \text{for } r > 1$$

Proof: by chl (3.4) there is an exact sequence with \mathbb{Z}_q coefficients

$$\rightarrow H_{r+1}(X) \xrightarrow{\partial} H_r(\tilde{X}) \xrightarrow{t_*^{-1}} H_r(\tilde{X}) \xrightarrow{P_*} H_r(X) \rightarrow$$

$H_r(X) = 0$ for $r > 1$, hence t_*^{-1} is injective for $r=1$ and an automorphism for $r > 1$. The corresponding exact sequence for the infinite cyclic cover $\tilde{X} \rightarrow \tilde{X}_q$ is

$$\rightarrow H_{r+1}(\tilde{X}_q) \rightarrow H_r(\tilde{X}) \xrightarrow{t_*^q - 1} H_r(\tilde{X}) \xrightarrow{P_*} H_r(\tilde{X}_q) \rightarrow$$

now $(t_*^q - 1) = (t_* - 1)^q$ over \mathbb{Z}_q (use here that q is prime), and this is injective for $r = 1$, and an automorphism for $r > 1$. Hence $H_r(\tilde{X}_q) = 0$ for $r > 1$, completing the proof.

(6.6) Corollary

If S_x and S_y are disjoint smooth 2-spheres in S^4 , and $\tilde{X}_{q,q}^{br}$ is the $\mathbb{Z}_q \oplus \mathbb{Z}_q$ cover of S^4 branched over S_x and S_y , then

$$H_2(\tilde{X}_{q,q}^{br}; \mathbb{Q}) = 0$$

Proof: Let N be a regular neighbourhood in S^4 of $S_x \cup S_y$, $X = \text{cl}(S^4 - N)$ then by duality in S^4 , $H_1(X; \mathbb{Z}) \cong 2\mathbb{Z}$ and $H_r(X; \mathbb{Z}_q) = 0$ for $r > 1$.

The $\mathbb{Z}_q \oplus \mathbb{Z}_q$ cover $\tilde{X}_{q,q}$ (unbranched) factors into two q -fold cyclic covers and applying the lemma to each of these covers in turn gives

$H_r(\tilde{X}_{q,q}; \mathbb{Z}_q) = 0$ for $r > 1$. By Universal coefficients, this implies

$H_2(\tilde{X}_{q,q}; \mathbb{Q}) = 0$ for $r > 1$. Let $p: \tilde{X}_{q,q}^{br} \rightarrow S^4$ be the branched cover,

$$\tilde{X}_{q,q}^{br} = \tilde{X}_{q,q} \cup p^{-1}(N) \quad \text{joined along } \partial\tilde{X}_{q,q} \text{ to } \partial p^{-1}(N)$$

The Mayer Vietoris sequence for this (coefficients \mathbb{Q}) is

$$\begin{aligned} \longrightarrow H_2(\tilde{X}_{q,q}) \oplus H_2(p^{-1}(N)) &\longrightarrow H_2(\tilde{X}_{q,q}^{br}) \longrightarrow H_1(\partial\tilde{X}_{q,q}) \xrightarrow{i_* \oplus j_*} \\ &\longrightarrow H_1(\tilde{X}_{q,q}) \oplus H_1(p^{-1}(N)) \end{aligned}$$

Now $p^{-1}(N) = \text{copies of } S^2 \times B^2$, hence $H_2(\partial p^{-1}(N)) \xrightarrow{\text{onto}} H_2(p^{-1}(N))$.

we will now show that i_* is injective, and so $H_2(\tilde{X}_{q,q}) \longrightarrow H_2(\tilde{X}_{q,q}^{br})$

is surjective, which proves the lemma. From the exact sequence of

$\tilde{X}_{q,q}$ and $\partial\tilde{X}_{q,q}$ (coefficients \mathbb{Q}):

$$\longrightarrow H_2(\tilde{X}_{q,q}, \partial\tilde{X}_{q,q}) \longrightarrow H_1(\partial\tilde{X}_{q,q}) \xrightarrow{i_*} H_1(\tilde{X}_{q,q})$$

the first term is dual to $H_2(\tilde{X}_{q,q})$ and so is zero, thus i_* is injective

as asserted, completing the proof.

Proof of (6.2). Form the double of $\tilde{X}_{q,q}^{br}$ (which is a cover of B^4 branched over two discs) and apply the preceding result, Mayer Vietoris now implies that $H_2(\tilde{X}_{q,q}^{br}; \mathbb{Q}) = 0$ as required.

57 Applications

The results of §3 and §5 are used in some simple applications mostly arising from the allocation of a definite sign to the Alexander polynomial and stated by Conway in (C). In this section the Alexander polynomial of a link will be used in the classical sense, so that it vanishes for $\beta(L) > 0$.

7.1 Definition

Suppose a knot k is formed from two oriented tangles a and b , then the knot k' obtained by rotating the tangle b about a vertical axis through an angle of π and then connecting to a is called a mutation of k . The string orientations must match up before and after.

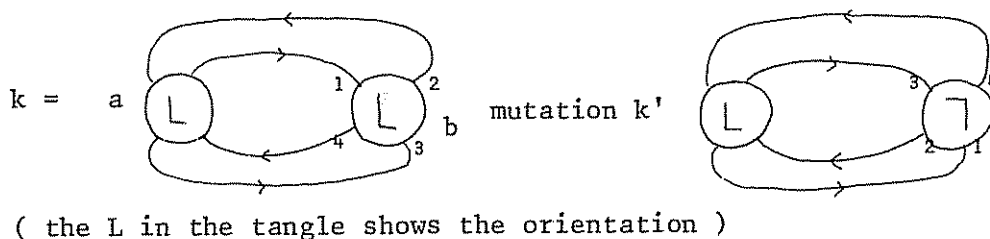

7.2 Proposition

If a knot k' is a mutant of a knot k , then k and k' have S -equivalent Seifert matrices (in the sense of Trotter).

Remark: this answers a question of Conway. Thus the classical invariants derived from the Seifert matrix cannot distinguish mutants.

Proof: by (3.5) there exists a Seifert surface for k which meets the 2-sphere round the b tangle in two arcs 1-2 and 3-4. Thus the surface outside the tangles may be assumed to be:

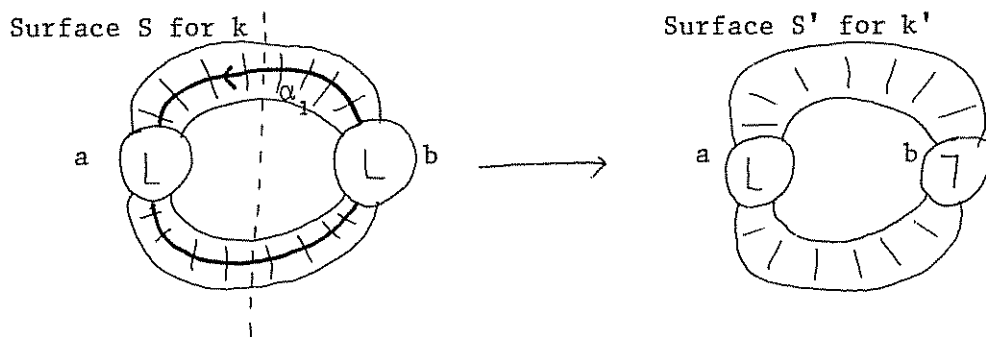

A surface S' for k' is obtained by cutting along the dotted line the surface S , rotating and glueing. Choose a basis of $H_1(S)$ such that only one representative, α_1 , traverses the dotted line as shown. Let $\alpha_2, \dots, \alpha_r$ represent a basis of H_1 (surface inside tangle b) and $\alpha_{r+1}, \dots, \alpha_n$ represent a basis of H_1 (surface inside tangle a). Then $\{\alpha_i\}_{1 \leq i \leq n}$ is a basis of $H_1(S)$. Let $\{\beta_i\}_{1 \leq i \leq n}$ be the naturally corresponding basis for $H_1(S')$. If A and B are the Seifert matrices for k and k' respectively then

$$A_{ij} = -B_{ij} \quad \begin{array}{l} \text{if } i = 1 \text{ and } 1 < j \leq r \\ \text{or } j = 1 \text{ and } 1 < i \leq r \end{array}$$

$$A_{ij} = B_{ij} \quad \text{otherwise.}$$

perform the change of basis for $H_1(S')$

$$\beta_i \rightarrow \begin{cases} -\beta_i & 1 < i \leq r \\ \beta_i & \text{otherwise} \end{cases}$$

then with respect to the new basis, the Seifert matrices are identical, completing the proof.

7.3 Normalising the Alexander polynomial

If a knot has Seifert surface V , and a Seifert matrix A , then $\det(tA - A')$ is independent of the surface chosen to within multiplication by $+t^n$. This may be proved by using the known relation (algebraic S -equivalence, ie matrix enlargements of a certain type) between different Seifert matrices for a knot. Another view is as follows.

The potential function for k is $\nabla(t) = \det(tA - t^{-1}A')$, where A is a Seifert matrix for k , then $\nabla(t) = \nabla(t^{-1})$ and so $\nabla(t)$ is certainly defined up to multiplication by ± 1 . It is known that $\sigma = \text{signature}(A + A')$ is an invariant of k , hence

$i^n \nabla(i) \equiv \nabla(1) \equiv 1 \pmod{2}$, where n is the number of rows of A , and so
 $i^n \nabla(i) > 0 \quad \text{IFF } \sigma - n \equiv 0 \pmod{4}$, hence $\nabla(i) > 0 \quad \text{IFF } \sigma \equiv 0 \pmod{4}$
 thus ∇ has a well defined sign. {In fact $\nabla(1) = 1$, because $A - A'$ has determinant $+1$ }

Turning now to a link L (of two components), define the potential function of L to be :

$$\nabla(x,y) = (-1)^{(k+\ell+2)/2} (x-1/x)^{-g} (y-1/y)^{-h} \det(xyA + (1/xy)A' - (x/y)B - (y/x)B')$$

$$\text{where } \ell = \text{Lk}(L_x, L_y) \quad g = 2\text{genus}(V_x)$$

$$k = \text{no. of clasps} \quad h = 2\text{genus}(V_y)$$

Then $\nabla(x,y) = \pm x^r y^s \Delta(x^2, y^2)$, and $\nabla(x,y) = \nabla(x^{-1}, y^{-1})$, and so ∇ is

certainly defined up to sign. It was proved in §5 that σ is an invariant

of L {for suitable ω_1, ω_2 }. Choose $\omega_1 = z_1^2$, $\omega_2 = z_2^2$ such that

$\nabla(z_1, z_2) \neq 0$ (ie $\Delta(\omega_1, \omega_2) \neq 0$). Let n be the number of rows of A , then:

$$\sigma = \text{signature}(z_1 z_2 + \bar{z}_1 \bar{z}_2) (z_1 z_2^A + \bar{z}_1 \bar{z}_2^A - z_1 \bar{z}_2^B - \bar{z}_1 z_2^B')$$

and:

$$(-1)^{(k+\ell+2)/2} (z_1 z_2 + \bar{z}_1 \bar{z}_2)^n (z_1 - \bar{z}_1)^g (z_2 - \bar{z}_2)^h \nabla(z_1, z_2) > 0$$

$$\text{IFF } \sigma - n = 0 \pmod{4}.$$

g and h are even, and $n = g+h+(k-1)$ and $k \equiv \ell \pmod{2}$ so this becomes

$$(z_1 z_2 + \bar{z}_1 \bar{z}_2)^{\ell+1} \nabla(z_1, z_2) > 0 \quad \text{IFF } \sigma \equiv \ell+1 \pmod{4}$$

thus ∇ has a well defined sign, in fact we show that $\nabla(1,1) = \ell$.

Re-phrasing the proof of (3.6 ii) in terms of ∇ instead of Δ shows that

$\det(xM + (1/x)M')$ depends only on ℓ , not on the particular link, and

evaluating at $x=1$ for a simple link gives $(-1)^{(k+\ell+2)/2}$ (see 4.7)

7.4 Proposition

$$\Delta(x,y) = (-1)^{(k+\ell+2)/2} (x-1)^{-g} (y-1)^{-h} \det(xyA + A' - xB - yB')$$

is defined up to multiplication by $\pm x^r y^s$, and $\Delta(1,1) = \ell$.

In the rest of this section, $\Delta(x,y)$ will be defined by (7.4), and \equiv

will mean equal up to multiplication by $\pm x^r y^s$. As Conway points out, there

are non-trivial consequences of a sign for the Alexander polynomial.

7.5 Definition

The link (or knot) obtained from a link L by reversing the orientation of S^3 (ie by changing crossovers and reversing string orientations) is denoted by $-L$. If $L = -L$, then L is called amphicheiral. The link obtained from L by reversing the orientation of the x string is denoted L_{-x} .

7.6 Theorem

$\Delta_L(x,y) \doteq -\Delta_{-L}(x,y)$ and $\sigma(\omega_1, \omega_2, L) = -\sigma(\omega_1, \omega_2, -L)$
 so if L is amphicheiral, $\Delta_L = 0$ and $\sigma = 0$ for all ω_1, ω_2 .

(The polynomial part is stated in (C))

Proof: If A, B are the linking matrices for L , $-A', -B'$ are linking matrices for $-L$, giving the signature result. $(xyA + A' -xB - yB')$ for L becomes $-(xyA + A' -xB - yB')$ for $-L$. The number of rows of A is $g+h+k-1 \equiv \ell-1 \pmod{2}$, and since g, h, k are the same for L and $-L$ but ℓ is multiplied by -1 , $\Delta_L \doteq (-1)^{\ell-1} (-1)^\ell \Delta_{-L}$, completing the proof.

7.7 Theorem

$\Delta_L(x,y) = \Delta_{L_{-y}}(x, 1/y)$ and $\sigma(\omega_1, \omega_2, L) = \sigma(\omega_1, \bar{\omega}_2, L_{-y}) \cdot (-1)^{\ell-1}$

Proof: If A, B are linking matrices for L , then B, A are the corresponding ones for L_{-y} . The result follows easily.

7.8 Proposition

If V_x, V_y are any Seifert surfaces for the components L_x, L_y of L , and ι is the geometric number of intersections of L_y with V_x then

$$\iota \geq |\tau(\omega_1, \omega_2, L)| - 2\{\text{genus}(V_x) + \text{genus}(V_y)\} + 1 - \beta(L) \quad \text{for all } \omega_1, \omega_2$$

Proof: Position L_y so that it intersects V_x ι times, and isotope the Seifert surface V_y for L_y to be transverse to L_x keeping ∂V_y fixed. The resulting 2-complex $V_x \cup V_y$ has at most ι clasps, the remaining intersections are circles or of ribbon type. Push in along arcs to convert all circles to ribbon type, of which there are now N say. Then push in along arcs to convert each ribbon into two clasps. In the proof of cobordism invariance of σ in §5, it was shown how to pick a basis of $H_1(S)$ with one loop going round each ribbon intersection, call these $\{\alpha_i\}_{1 \leq i \leq N}$. Then the linking forms vanish on the space spanned by these and so:

$$\begin{aligned} |\tau(\omega_1, \omega_2, L)| &\leq \text{size of } A + \text{nullity}(xyA + A' - xB - yB') - 2N \\ &= 2N + \iota - 1 + 2\text{genus}(V_x) + 2\text{genus}(V_y) + \beta(L) - 2N \end{aligned}$$

giving the result.

7.9 Identities between Alexander polynomials

These results have been proved by Conway (although the proofs have not been published). His method of proof, I understand, is to use the Wirtinger presentation of the fundamental group, and associate each generator (arising from an arc) with the crossing to which it points (using the string orientation). This association is preserved through the free differential calculus, so that the presentation matrix M for π''/π' behaves like a quadratic form under change of basis. This approach has been used by Kearton (Kea) to produce the signature invariants of Milnor (Mil). The proofs which follow arise by using related Seifert surfaces for related knots and links. In what follows Seifert surfaces will be used which are specified on the outside of various tangles, this is justified by use of (3.5)

First Identity

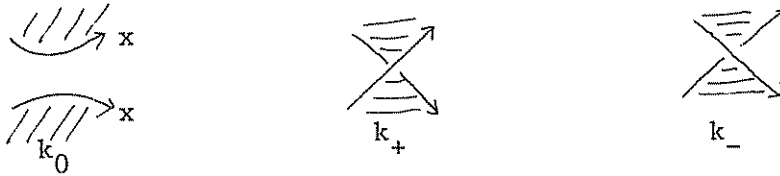

Suppose \$k_0\$ (a knot or link) becomes \$k_+\$ and \$k_-\$ by replacement using the tangles shown. Surfaces are chosen which are identical outside the tangle depicted, and inside are as shown. If \$A\$ is a Seifert matrix for \$k_0\$ then

$$\begin{bmatrix} n & -\mu & - \\ | & & \\ v_1' & A & \\ | & & \end{bmatrix} \quad \begin{bmatrix} n-1 & -\mu & - \\ | & & \\ v_1' & A & \\ | & & \end{bmatrix}$$

are Seifert matrices for \$k_+\$ and \$k_-\$, from which it follows (on expanding determinants):

$$(x - (1/x)) \nabla_{k_0} = \nabla_{k_+} - \nabla_{k_-}$$

(Kauffman has also given this proof in (K)).

Second Identity

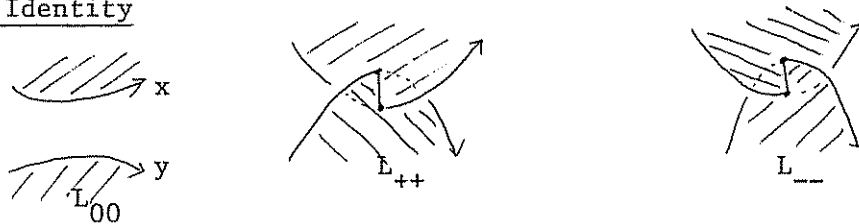

Suppose that \$L_{00}\$ yields \$L_{++}\$ and \$L_{--}\$ on replacing the tangle shown as depicted. A \$C\$-complex for \$L_{00}\$ may be chosen so that one for \$L_{++}\$ and \$L_{--}\$ arises by adding one extra clasp as shown. \$L_{00}\$ has linking matrices \$A, B\$ say, with linking number \$\ell\$ and \$k\$ clasps, then

\$L_{++}\$ has:

$$\begin{bmatrix} 0 & -\mu_1 & - \\ | & & \\ v_1' & A & \\ | & & \end{bmatrix} \quad \begin{bmatrix} 0 & -\mu_2 & - \\ | & & \\ v_2' & B & \\ | & & \end{bmatrix} \quad k+1 \text{ clasps,} \quad \text{linking number } \ell-1$$

\$L_{--}\$ has:

$$\begin{bmatrix} -1 & -\mu_1 & - \\ | & & \\ v_1' & A & \\ | & & \end{bmatrix} \quad \begin{bmatrix} 0 & -\mu_2 & - \\ | & & \\ v_2' & B & \\ | & & \end{bmatrix} \quad k+1 \text{ clasps,} \quad \text{linking number } \ell+1$$

on expanding determinants, and remembering the sign for ∇ , gives:

$$\nabla_{L_{++}} + \nabla_{L_{--}} = (xy - (1/xy))\nabla_{L_{00}}$$

which is the second identity.

7.10 An identity for Polychrome Signature

The following observation is due to Conway. We saw earlier that

$$\sigma(\omega_1^2, \omega_2^2) \equiv \ell+1 \pmod{4} \quad \text{IFF} \quad (\omega_1\omega_2 + \bar{\omega}_1\bar{\omega}_2)^{\ell+1}\nabla(\omega_1, \omega_2) > 0$$

and in any case $\sigma \equiv \ell+1 \pmod{2}$, and

$$|\tau(\omega_1^2, \omega_2^2, L_{00}) - \tau(\omega_1^2, \omega_2^2, L_{++})| \leq 1$$

these two facts enable $\sigma_{L_{++}}$ to be computed from a knowledge of $\sigma_{L_{00}}$

and the potential functions involved. Polychrome signatures may thus be calculated in practise by pulling apart clasps one at a time, until a split link is obtained, for which the signature splits into ordinary knot signatures ie

$$\sigma(\omega_1, \omega_2, L) = \sigma(\omega_1, L_x) + \sigma(\omega_2, L_y) \quad \text{for a split link.}$$

§8 Further Remarks and Problems

- 1) It would be nice to have a proof of (2.3) and (2.4) on the polynomial and signature of a slice link based on Levine's proof of the null cobordance of a Seifert matrix for a slice knot. I do not know if it is the case that for any C -complex of a slice link there is an $(n+1)$ dimensional subspace of $H_1(S)$ (dimension = $2n+1$) on which α and β vanish. If true this would seem to be stronger than present results.
- 2) It seems that if $\omega_1^p = 1 = \omega_2^q$ then $\sigma(\omega_1, \omega_2, L)$ is closely related to $\sigma(\omega, L')$ where L' is obtained from L by replacing L_x and L_y by cable knots (or links) around them, and $\omega^{pq} = 1$.
- 3) Are the Torres conditions sufficient when both components are unknotted ?, yes if $|\ell| \leq 2$ where ℓ is linking number.
- 4) For links of more than two components, Seifert surfaces may be chosen so that all intersections are clasps (no triple points) so for n components there are 2^n possible ways of pushing a cycle off the C -complex. This makes the approach less manageable.
- 5) By using the Isotopy lemma, it is possible to characterise 'S-equivalence' of matrix pairs algebraically.
- 6) C -complexes and their signatures can be handled in the generality of chapter 1.

References

- AS M.F. Atiyah and I.M. Singer, The Index of Elliptic Operators III;
Ann of Math 87 (1968) 546-604
- B J.H. Bailey, Alexander Invariants of Links, Ph D thesis, University
of British Columbia 1977
- Bla R.C. Blanchfield, Intersection Theory of Manifolds with Operators
with applications to knot theory. Ann Math 65 (1957) 340-356
- C J.H. Conway, An Enumeration of knots and links and some of their
algebraic properties. Computational problems in Abstract Algebra
Pergamon Press, Oxford and New York, 1969, 329-358
- CG1 A.J. Casson and C.McA Gordon, On Slice knots in Dimension Three,
Proc. Symposia in Pure Maths, Vol 32, 1978, p39-52
- CG2 A.J.Casson and C.McA Gordon, Cobordism of classical knots,
mimeographed notes, Orsay 1975
- Gil P.M. Gilmer, Slice knots in S^3 , Preprint, Yale University, New
Haven, Connecticut
- H J.A. Hillman, The Torres conditions are Insufficient, Math Proc
Cambridge Philos. Soc. 89 (1981) 19-22.
- Kau L.Kauffman, The Conway Polynomial, Topology 20 (1981) 101-108
- Kaw A. Kawauchi, On The Alexander Polynomial of Cobordant Links,
Osaka J. Math, 15 (1978) 151-159
- Kaw2 A. Kawauchi, On Quadratic forms of 3-manifolds, Inventiones Math.
43, 177-198, (1977)
- Ke C. Kearton, Signatures of Knots and the free differential Calculus
Quart. J. Math. (Oxford) 30, 1979, 157-182
- L J. Levine, A Method for generating Link polynomials, Amer J. Math
89 (1976) 69-84.

- L2 J. Levine, Knot Cobordism in Codimension two, *Comment. Math. Helv.* 44 (1969) 229-244
- Li R.A. Litherland, Signatures of Iterated Torus knots. LNM 722
Topology of Low-dimensional Manifolds, Sussex 1977
- Mil J.W. Milnor, Infinite cyclic coverings, Conference on the Topology of Manifolds. Prindle, Weber, Schmidt. Boston Mass. 1968, p115-133
- N Y.Nakagawa, On The Alexander Polynomial of Slice Links, *Osaka J. Math* 15 (1978) 161-182
- R D. Rolfsen, Knots and Links, Mathematics Lecture series 7, Publisher Perish Inc, Berkeley, Ca. 1976
- Sum D.W. Summers, On the Homology of finite cyclic coverings of higher dimensional Links. *Proc AMS* 46 (1974) 143-149
- Tor G. Torres, On the Alexander Polynomial, *Ann of Math* 57 (1953) 57-89
- T A.G. Tristram, Some Cobordism Invariants for links, *Proc Cambridge Philos. Soc.* 66 (1973) 251-264.
- T1 H.F. Trotter, On S-Equivalence of Seifert matrices, *Inventiones Math* 20 (1973) 173-207
- V O.Ja Viro, Branched coverings of Manifolds with boundary and Link Invariants I, *Math USSR Izvestiji* 7 (1973) 1239-1256 (Russian)
MR 51#6832
- G C.Mc A. Gordon, Some Aspects of Classical Knot Theory. LNM 685
Proceedings, Plans-sur-Bex, Switzerland 1977